

PALFINGER

LIFETIME EXCELLENCE

P 300
PREMIUM CLASS



TECHNICAL SPECIFICATIONS

Max. working height	30 m
Max. cage bottom height	28 m
Max. outreach to the side*	20,7 m
Max. outreach*	20,9 m
Angle of main boom	540°
Rotation angle of cage	2 x 85°
Rotation angle of cage boom	195°
Max. cage load	350 kg
Size of cage	1,8 x 0,8 x 1,1 m
Permissible inclination of platform	5°
Height in transportposition*	3,5 m
Width in transportposition	2,52 m
Overall length*	8,96 m
Wheelbase*	4,22 m
Total weight*	7200 kg

* Depends on truck chassis

STANDARD EQUIPMENT

Aluminium board wall
Memory function
Home function
Automated positioning system
Battery voltage monitor
Safety plates
230 V CEE current supply with CEE socket in the workman cage

WORKING DIAGRAMS

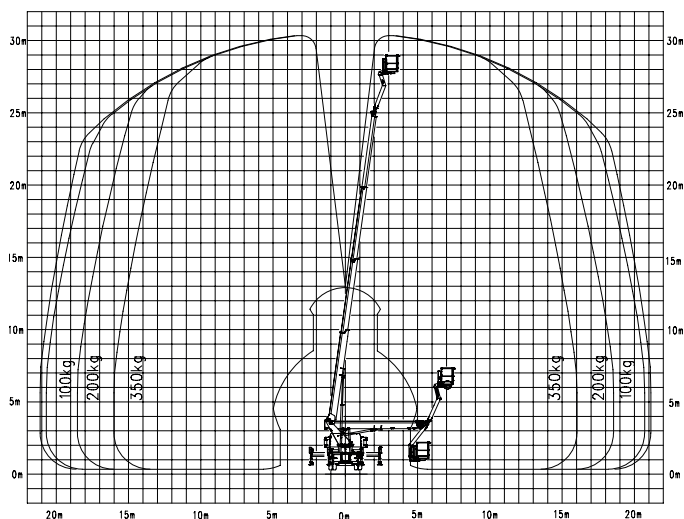

Abstützung beidseitig, breit

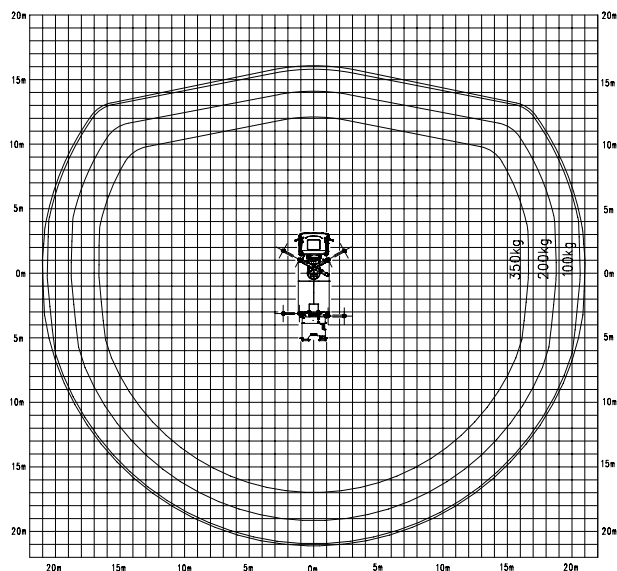

A possible 2% tolerance is contingent on structural components

DIMENSIONS

