

ecolift

4.2m Non-Powered, Powered Access

Operating and Maintenance Manual



**POWER
TOWERS**

Low-level Powered Access

a JLG company

www.powertowers.com

CONTENTS

Introduction 2

Operating Specifications 3

Working Envelope Diagram 3

Do's and Don'ts 4

Primary Components 5

Operating Procedures (Incl. Emergency Operation) 6-8

Maintenance Procedures 9-11

Castor Safety and Maintenance 12

Transportation, Towing, Lifting and Manoeuvring 13-14

Storage 15

Key Spare Parts 16

Warranty Terms 17

Decal Placement 18-21

Wind Rated Chassis - Operating Specifications Appendix 'A'

Wind Rated Chassis - Operating and Safety Instructions Appendix 'B'

Wind Rated Chassis. Additional Maintenance Instructions Appendix 'C'

Machines with ATEX Certification Appendix 'D'

INTRODUCTION

The Power Tower Ecolift is a simple, safe and efficient alternative to step-ladders, platform/podium steps and small scaffold towers. The Ecolift does not require batteries (or charging) or connection to an electricity supply. It works by a unique, patented stored power mechanism which enables the platform to be elevated with very little effort by the operator.

The Ecolift is designed for working internally on flat, level surfaces, and as it has no batteries, electric motor, electrics or hydraulics it is very ecologically friendly. It is ideally suited to working in a very wide range of applications from the very 'clean' environments of hospitals, food and drinks production facilities, pharmaceuticals and retail, to facilities maintenance, shop-fitting and indoor construction and even on zone 1/21 hazardous areas (If ATEX option is fitted).

The Ecolift is suitable for any application provided it is used within its specified operating parameters. If used for applications such as sand blasting, welding, paint spraying or with any other hazardous materials, measures must be taken to ensure the Ecolift does not become damaged in any way which may impair safety, or reliability. Additional protection for the operator may be required in some cases, which is the responsibility of the operator and/or the operator's employer.

The purpose of this manual is to provide essential basic information required to operate and maintain the Ecolift.

This is not a workshop manual. Please contact the manufacturer or their agent for specific operation or maintenance information if in doubt.

The health and safety of the operator or maintenance technician is the responsibility of the individual and/or their employer and not Power Towers Ltd.

OPERATING SPECIFICATIONS

Working Dimensions

Maximum working height:	4.20 m
Maximum platform height:	2.20 m
Platform dimensions:	850 mm (L) x 644 mm (W)
Working footprint:	1280 mm x 740 mm
Safe working load:	150 kg (1 person + tools)
Maximum manual force:	200 N
Maximum gradient for operation:	0 degrees
Maximum wind force:	Internal use only, 0 (zero) mph
Maximum wheel force:	234 kg
Maximum castor point load:	234 kg (2.29kN)
Sound pressure level:	Less than 70dBa

Closed Dimensions

Length:	1280 mm
Width:	740 mm
Height:	1950 mm
Weight:	305 kg

Lift Cycles: Unlimited, subject to maintenance program being adhered to.

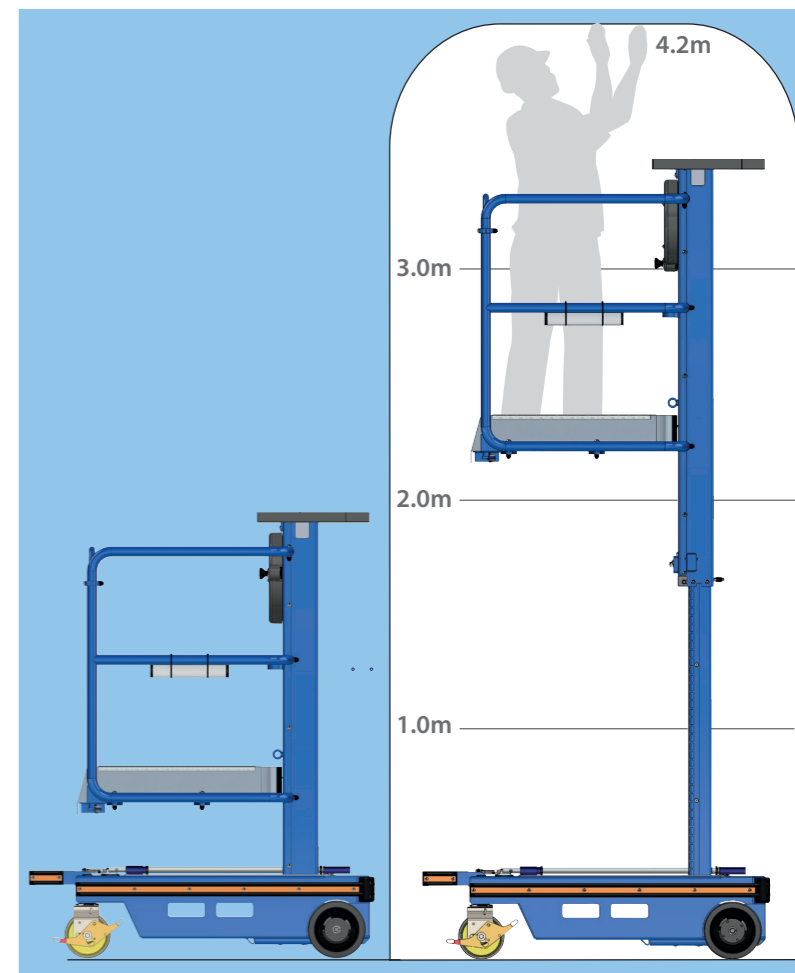

DO'S

1. Read and adhere to the instructions both on the machine and in the Instruction Guide or Operating Manual.
2. Ensure pre-operation checks & operations are carried out in the manner described.
3. Use only on hard, level surfaces able to support the weight of the machine.
4. Use the Ecolift internally only.
5. Ensure the operator is fit and does not suffer from a fear of heights.
6. Ensure guardrail gates are closed before elevation.
7. Ensure work area around the machine is cordoned off from pedestrians and other traffic.
8. Ensure operator is wearing the correct safety equipment.
9. Ensure the platform is correctly positioned so as not to come into contact with fixed or moving objects.
10. Ensure that the safe working load is evenly distributed on the platform.
11. Ensure the machine is being operated within the PUWER (Provision and Use of Workplace Equipment Regulations).
12. Ensure the castor brakes are applied when leaving the machine unattended.

DON'TS

1. Never exceed the safe working load (1 person plus tools, 150kg).
2. Never use the Ecolift as a goods lift or crane.
3. Never exceed horizontal forces, (maximum horizontal force 200N).
4. Never use in the vicinity of live conductors.
5. Never try to move the Ecolift on its wheels when elevated.
6. Never extend the height of the platform by using boxes, steps, ladders etc.
7. Never modify the Ecolift in any way without the full written approval of the manufacturer.
8. Never attempt to enter or exit the platform unless it is fully lowered.
9. Never use the Ecolift on sloping or uneven ground.
10. Never operate the Ecolift outdoors, or anywhere it may be affected by wind.
11. Never lift heavy components on the Ecolift without the use of the correct lifting equipment.
12. Never use the Ecolift in an explosive environment.
13. Never use the machine if you are fatigued.
14. Never use the machine inappropriately or for 'horseplay'.
15. Never use the machine if under the influence of drugs or alcohol.
16. Never use the machine if suffering from poor health or using medication which might impair the safe operation of the Ecolift.
17. Never use the Ecolift if vision impaired by bright lighting.
18. Never push the Ecolift on sloping surfaces without the use of a safe method.
19. Never push or pull objects with the platform.
20. Never use on uneven surfaces.

PRIMARY COMPONENT LOCATIONS

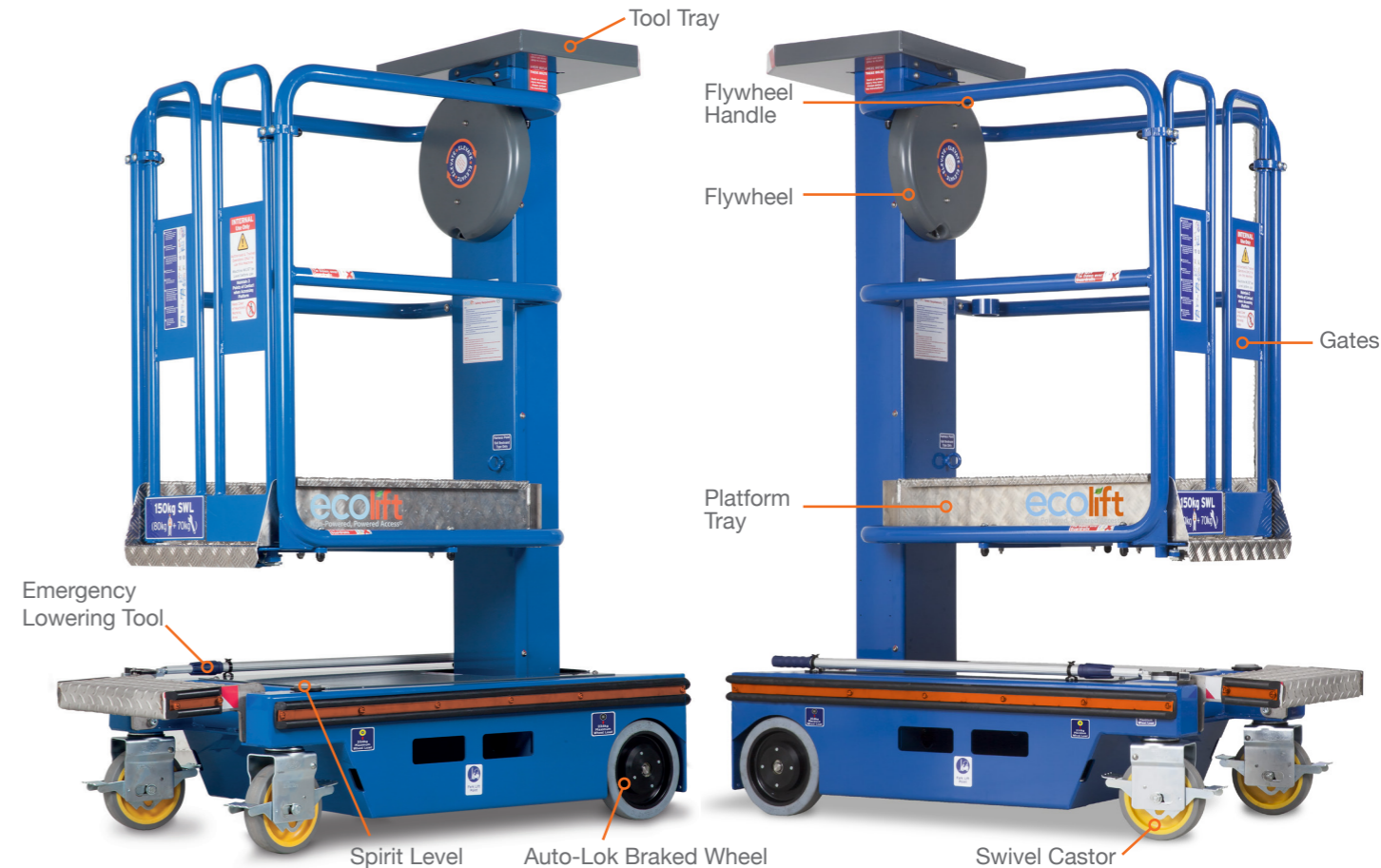

OPERATING PROCEDURES

It is essential to be familiar with the correct operating procedures. The operator must have adequate training for this type of platform.

The Ecolift is fitted with a safety harness point. If after conducting a risk assessment the operator chooses to wear a safety harness, an approved 'fall restraint' type harness should be worn with a very short lanyard.

Operating procedures are divided into three key areas:

1. Pre-operation checks.
What to do before operating the Ecolift.
2. Normal operation.
How to use the Ecolift safely.
3. Emergency operation.
How to lower the Ecolift in the event of operator incapacity.

It is the owners and/or the users responsibility to ensure that the machine is maintained and operated in accordance with the operation and maintenance procedures contained within this manual.



PRE-OPERATION CHECKS

1. Visually inspect the Ecolift for any signs of damage to handrails, platform tray, chassis and mast lifting structure including mast fixing bolts.
2. Check castors and wheels rotate freely and are undamaged.
3. Check castors (pic 1) and wheel fixings (pic 2) are secured with split pin.
4. Check spirit level (pic 3) is intact and bubble is centred to ensure machine is level.
5. Check gates, gate hinges, hinge springs and hinge fixings are undamaged and that gates open and close correctly (pic 4).
6. Ensure step is lowered and secure.
7. Check castors are not loose or distorted in any way. If okay, lock by stepping on the pedal marked 'lock' or stepping on the red pedal, depending on which castor is fitted, then step into the basket.
8. When standing in the basket: check 'fly-wheel' operating handle works correctly. Hold handle firmly and pull operating knob towards you, release, knob should spring back to lock wheel. Repeat but turn handle once clockwise with knob held pulled towards you. Wheel should turn freely. Turn once anti-clockwise to come down (pic 5).
9. Check emergency lowering tool is attached on the chassis.

If any of the above items are faulty or do not work correctly then do not use the machine.

NORMAL OPERATION

Only use the Ecolift internally, on hard level surfaces. Ensure a person is available at ground level to assist in case of emergency.

1. Position machine under application.
2. Check spirit level to ensure machine is level.
3. Ensure castors are in the locked position as described in pre-operation checks.
4. Step into platform through gates, ensure gates close behind you.
DO NOT ELEVATE IF they are not closed.
5. Check there are no overhead obstructions.
6. To elevate: pull operating knob towards you and turn clockwise.
To stop, stop turning the handle and release handle knob to lock.
7. To descend repeat but turn handle anti-clockwise.

Note: Do not attempt to turn the flywheel handle when there is NO payload in the platform .i.e. when standing outside the platform guardrails.

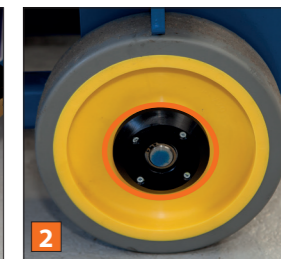

The user shall obtain the guidance and approval of the manufacturer in the event of any special working methods or conditions outside those specified by the manufacturer.

EMERGENCY LOWERING OPERATION

Never attempt to recover the machine/operator if there is any possibility the machine is contacting any live wiring/cabling and is therefore potentially 'live'.

To lower the platform in the event of the operator being incapacitated (unable to operate the flywheel handle in the basket):

1. Locate emergency lowering tool on chassis (pic 1), remove from fixing.
2. Stand to side of machine, attach 'hook' end of emergency lowering tool to flywheel handle knob in basket, releasing handle knob, turn wheel **anti-clockwise** to bring platform down (pic 2).
3. Keep clear of structure as it descends.
5. Depending on the height of the elevated platform, it may be necessary to extend the shaft of the tool.

Turn the shaft lock anti-clockwise to extend and retract the shaft, and clockwise to lock to the desired position.



Never attempt to engage the emergency lowering tool without an operator in the platform.

Turn wheel **anti-clockwise** to bring platform down

Please note that whilst the Ecolift is extremely simple to maintain, all work must be carried out by a competent person.

NOTE: PUWER (The Provision and Use of Workplace Equipment Regulations 1998) stipulates that suppliers such as hire companies must ensure their equipment is maintained correctly and fully serviced. Once on site, it is the hirer/ employer's responsibility to ensure the machine remains in serviceable condition. The hirer/employer must also ensure the operator is properly trained and familiarised with the machine and the manufacturers operating procedures.

The health and safety of any operator or maintenance staff is the responsibility of the individual and/or their employer.

DAILY MAINTENANCE

Note: The telescopic mast is a sealed unit which contains a pressurised cylinder and can only be dismantled by a trained person authorised by the manufacturer.

The most important regular maintenance to be carried out by the operator is visual inspection, as per the pre-operation checks.

Daily Checks

The safety critical items to inspect each work session, daily as a minimum are:

1. Check there is no damage to the following: wheels and castors and check that their fixings are secure. These are the components

that connect the machine to the ground; if they are damaged then operating the machine could be dangerous and may result in serious injury.

2. Check that the guardrails are not damaged and all fixings are secure.
3. Check gates and gate hinges are secure and gates close freely. Ensure gates cannot open outwards.
4. Check chassis is not damaged and spirit level is intact and working.
5. Check mast fixings are all present and secure.
6. Check flywheel handle operates correctly: step into the platform to do this (do not attempt to operate the handle from outside the basket). Pull flywheel handle knob towards you, release. Ensure handle springs back to lock wheel. Turn wheel one revolution clockwise then anti-clockwise; ensure handle moves freely in either direction.
7. Check automatic wheel-brake works by: repeat no. 6 when platform is elevated approximately 100mm, and with the assistance of a colleague, attempt to push the machine, machine should not move, wheels should be braked.
8. Check emergency lowering tool is attached to chassis and not damaged. Check pivot and spring for signs of fatigue

Monthly Checks

As daily checks (items 1-8).

SIX MONTHLY CHECKS - LOLER

1. Remove handle cover using suitable security screw tool and inspect and lubricate gearwheels. Use Omega 73 no. 2 harsh environment grease or equivalent. Do not use standard gear grease because it will dry out prematurely and will lead to premature gear wear. Paint seal screws when refitted.
2. The machine should be subjected to the test procedure below:
 - a) Fully lower platform to the transport position.
 - b) With a calibrated digital spring balance apply a further 25kg force to the drive handle in the anti-clockwise direction (lowering), first releasing the handle knob from the back plate to allow the handle to turn (see fig A).
3. Inspect the drive belt for signs of wear. In order to do this, remove the tool tray and mast cap plate. The mast cap screws are additionally secured with a threadlock adhesive. If difficulty is experienced removing these screws then they will need to be heated with a heat gun for a few minutes. With this cover removed a full visual inspection of the belt and pulleys can be made. The platform can be raised and lowered fully whilst viewing the belt and pulleys. Minor scuffing and wear is acceptable, but there should be no signs of the inner braided wire or Kevlar cords visible. If there are any signs of excessive wear, contact the manufacturer or authorised distributor. When complete, refit the mast cover and refit the fixing screws with a medium strength threadlock. Paint seal screws when refitted. Refit tool tray. It is extremely important that these bolts be replaced correctly.
4. Check the mast interlock is undamaged. Check the casing for signs of damage and remove the end plate. (Pic 1, shows mast interlock with cover on). Check the plunger is free to move by

- holding end with long nosed pliers and pulling outward and then releasing (Pic 2). Ensure plunger springs back freely. Refit cover and screw. Paint seal screw when refitted.
5. Inspect condition of automatic wheel lock. Look under brush strip at rear of chassis when platform is elevated so that mast outer is clear of chassis. Check brake cam plates (Pic 3 and Fig B) are undamaged and that the two attaching screws are tight. With an assistant to lower the platform, observe the action of the cams and the movement of the brake pins. Ensure the movement is free and the pins clear the wheel discs. When the platform is elevated ensure the pins fully engage the brake discs. Ensure the pockets in the wheels are in good condition.
 6. Check all instruction labels are present and clear. Refer to the key spare parts. Check aluminium specification plate is clear and legible.
 7. Check crank handle knob is securely fixed with M12 nyloc nut and roll pin through plastic tip. Ensure handle springs back to the locked position freely.

When replacing components for any reason, only use OEM specification parts, either supplied from the manufacturer or authorised in writing by the manufacturer. Warranties and design approvals will be void if alternative components are fitted. It is essential to obtain manufacturer's approval of any alteration which might affect stability, strength or performance in writing before proceeding.

When refitting a rear wheel always use a new cotter pin (4mm diameter x 32mm A2 stainless steel). NEVER REFIT A USED COTTER PIN.

8. Ensure platform entrance gates open and close freely and that they self-close when released. Check pivots and springs for signs of fatigue and damage.
9. Check rear wheels for signs of damage and that they rotate freely. Ensure there is no cut or wear to wheel that penetrates more than 4mm in depth. The original wheel diameter is 200mm.
10. Check castor condition in accordance with the following procedures.

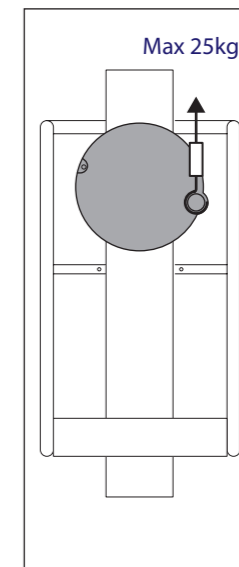

Fig A

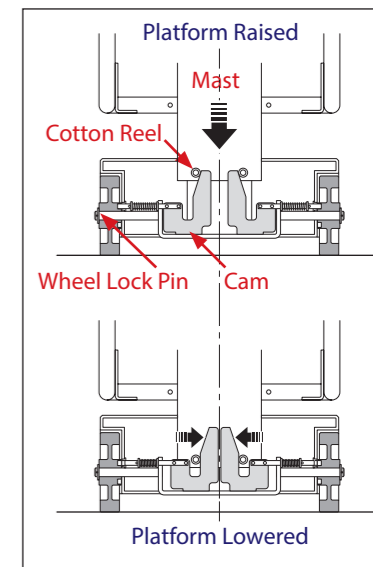
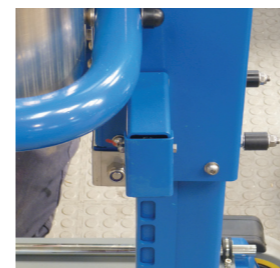

Fig B



Pic 1. Mast interlock with cover on



Pic 2. Interlock pull twist.



Pic 3. Brake cam view.

Important. These instructions apply to all Ecolift machines BEFORE Serial no. 8872815H (also including 9522915H, 9532915H, 9542915H, 9552915H, 10093115H)

CASTOR SAFETY & MAINTENANCE

In order to ensure the Ecolift castors are maintained in serviceable and safe condition, regular inspection is required, especially where arduous conditions are known to be involved or there is a suspicion of misuse or abuse. The other key element to ensure is in safe serviceable condition, is the castor fixing bolt, the condition of which can usually be determined from the condition of the castor bracket.

The castor is highly rated for the application so if visible distortion is evident a significant impact will have occurred and under these conditions the castor and fixing must be replaced.

Typical signs of impact which would require castor and fixing replacement:



Side impact and foot pedal distortion as a result of a significant side impact.
 Foot pedal distortion as a result of a significant frontal impact; it is likely the top plate and bearing will be distorted as well.
 Top mounting plate distortion as a result of a single significant impact or multiple lower level impacts. **Even if the rest of the castor is in good condition, it must be replaced.**

It may be thought feasible to repair the castor in a number of these instances, but serious structural damage will have occurred to the head bearing and castor assembly as well as possibly damage to the main mounting bolt.

When inspecting a castor in order to determine its serviceability, pay particular attention to the head swivel bearing (compare to a new one if possible) and the boss/rievet which goes through the centre of the swivel bearing and which clamps the assembly together.

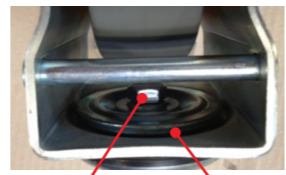

Castor mounting bolt Swivel bearing head should feel free to rotate and not loose

If the castor is in sound condition, free from distortion then it may be adequate to only replace the main fixing bolt with one of a higher tensile strength, along with a spacer washer that enables a higher bolting torque to be applied. This will improve the reliability of the fix, but will not increase the strength of the castor assembly. The new fixing nut and bolt are to be re-torqued to 55Nm.

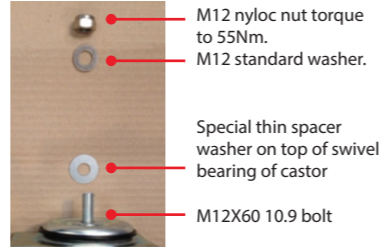

In order to replace the fixing bolt, the wheel axle bolt, half nut and star washer will first need to be removed, along with the central bushing tube and M12 end washers. This enables the wheel to be removed so that the castor fixing bolt can be replaced.

When refitting the wheel, the axle bolt, half nut and star washer, must be replaced with OEM specification new parts and re-torqued to 80Nm (Pic A). Ensure the axle tube and assembly is lightly greased to ensure a smooth action when operating the foot brake.

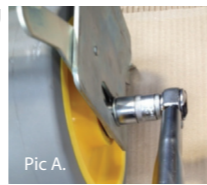

Power Towers Limited strongly recommends replacing any castor assembly that is over 3 years old with a new one.

Important. These instructions apply to all Ecolift machines FROM serial no. 8872815H (NOT including 9522915H, 9532915H, 9542915H, 9552915H, 10093115H).

CASTOR SAFETY & MAINTENANCE

In order to ensure the Ecolift castors are maintained in serviceable and safe condition, regular inspection is required, especially where arduous conditions are known to be involved or there is a suspicion of misuse or abuse. The other key element to ensure is in safe serviceable condition, is the castor fixing bolt, the condition of which can usually be determined from the condition of the castor bracket.

The castor is highly rated for the application so if visible distortion is evident a significant impact will have occurred and under these conditions the castor and fixing must be replaced.

Typical signs of impact which would require castor and fixing replacement.

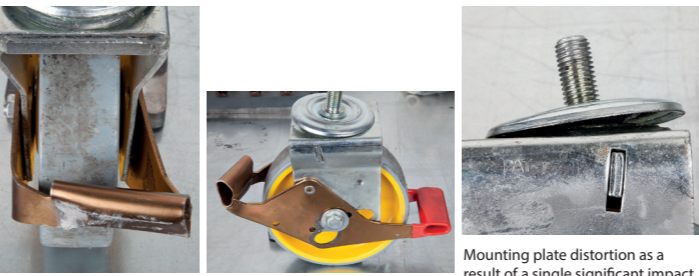

Foot pedal distortion as a result of a significant impact; it is likely the top plate and bearing will be distorted as well.
 Mounting plate distortion as a result of a single significant impact or multiple lower level impacts. **Even if the rest of the castor is in good condition, it must be replaced.**

It may be thought feasible to repair the castor in a number of these instances, but serious structural damage will have occurred to the head bearing and castor assembly as well as possibly damage to the main mounting bolt.

When inspecting a castor in order to determine its serviceability, pay particular attention to the head swivel bearing (compare to a new one if possible) and the boss/rievet which goes through the centre of the swivel bearing and which clamps the assembly together.



Underside of Castor
 Castor mounting bolt Swivel bearing head should feel free to rotate and not loose

**Castor Fixing Bolt (3/4 UNC): Torque - 120 Nm
 Castor Axle Bolt: Torque - 40 Nm**

TRANSPORT INSTRUCTIONS

It is the responsibility of the transport driver to ensure the Ecolift is safely secured to the transport vehicle.

Ensure that the transport vehicle has the load capacity and dimensions in order to safely carry the weight and size of the Ecolift.

Ensure that loading straps/chains are of adequate capacity to safely secure the Ecolift for transport.

Always ensure that the Ecolift is transported in the upright position. Never lay flat.

Ensure the transport vehicle is parked on a level surface and the parking brake is applied.

The Ecolift can be loaded via a forklift, tail-lift, or winch. Never push the Ecolift up a slope without the aid of a winch.

If using a forklift, raise the Ecolift by approximately 50 - 100mm so that the front wheel brakes engage.

Ensure the castor wheel locks are operated and that the forklift tines are fully engaged through the chassis sockets.

Load the Ecolift onto the transport vehicle, taking care to position the machine so that straps can be located around the base of the machine without the need for the driver to have to climb onto the bed of the vehicle. Note; only trained qualified forklift drivers are to load the Ecolift.

Use at least two straps, with one strap over the chassis, around the mast section and out to the rear of the machine. The other strap should be fed through the front of the chassis and the straps taken forward, so that the machine is tied down in four diagonal directions. Never place the strap over the platform or handrails.

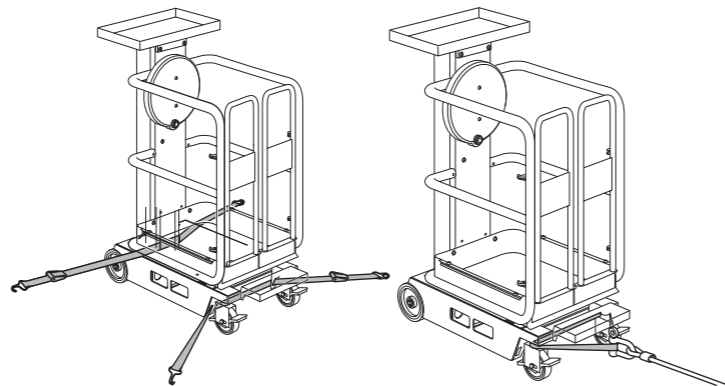

Loading

If loading with the aid of a winch up a ramp to the trailer, connect the winch cable to the castor/gate end of the chassis around the tops of the swivel castors, and then connect the winch cable to the strap.

Ensure the castor brakes are unlocked, and that the platform is fully lowered in the transport position. Before disconnecting the Ecolift from the winch cable, engage the castor brake.

If loading with the aid of a tail lift, ensure the tail lift has adequate load capacity and dimensions in order to safely lift the Ecolift. Ensure the tail lift and vehicle is on flat ground.

Ensure the platform is fully lowered to the transport position and wheel onto the tail lift bed. Once correctly positioned on the bed, lock the swivel castor brakes.

Raise the tail lift to the vehicle bed height. Unlock the castors and manoeuvre to the desired location on the vehicle and tie down as described above.

Towing

It is the responsibility of the driver to ensure safe practice is employed in order to access the vehicle bed in order to manoeuvre the Ecolift and then tie it down. One option is for the vehicle to be fitted with suitable guarding to prevent the possibility of the driver from falling to the ground.

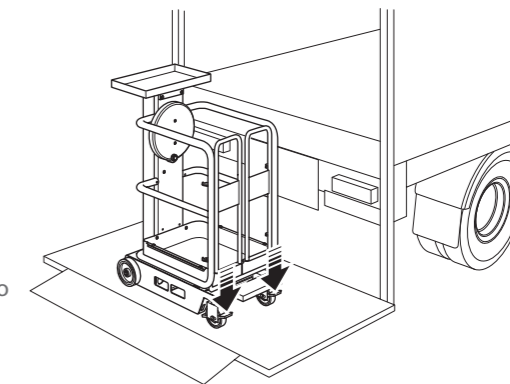

How to manoeuvre

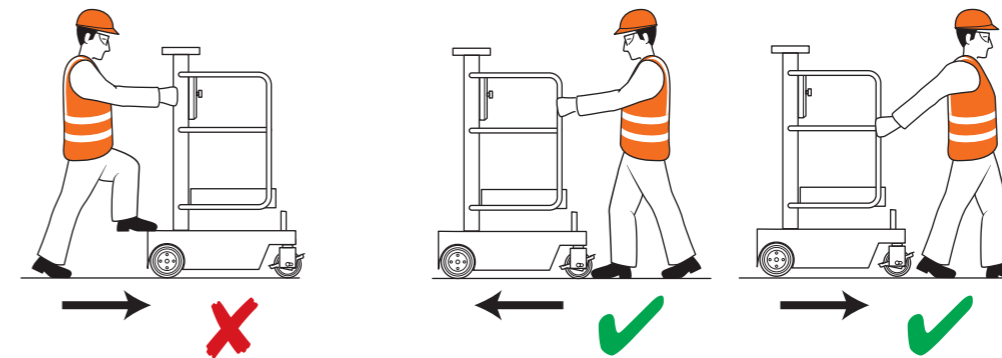

STORAGE

If the machine is due to be stored for periods in excess of one month, the following precautions should be taken: ensure the machine is fully lowered and ideally place a cover over the machine.

Only store or transport the Ecolift in an upright position.

Upon removal from storage and prior to returning to use, ensure machine pre-operation checks are carried out thoroughly, check LOLER certificate is current.

		Part No.
A	Swivel Castor*	PT-M-102
B	Swivel Castor**	PT-M-102-2
C	Spirit level	PEL-M-451
D	Wheel	ECL-M-600
E	Tool Tray	ECL-M-601
F	Chassis Cover	ECL-M-602
G	Flywheel	ECL-M-603
H	Ecolift Gates (pair)	ECL-M-700
I	Step	ECL-M-701
J	Emergency Lowering Tool	ECL-M-703
K	Platform Tray	ECL-M-704
L	Ecolift Decal Set 1	ECL-M-800
M	Ecolift Decal Set 2	ECL-M-802

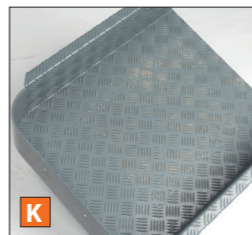
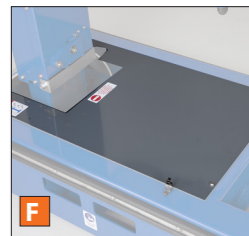
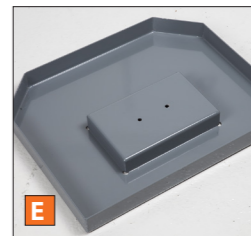
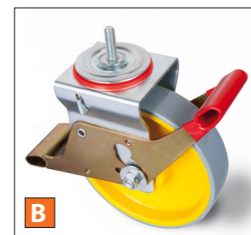
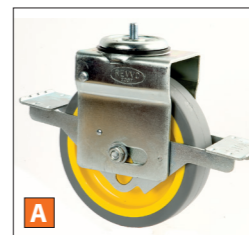

CASTOR CHANGES:

* BEFORE SERIAL NO. 8872815H
(also including 9522915H, 9532915H,
9542915H, 9552915H, 10093115H)

**FROM SERIAL NO. 8872815H (Not
including 9522915H, 9532915H,
9542915H, 9552915H, 10093115H).

WARRANTY

Your Ecolift is covered by an 18 month parts/components warranty. The Manufacturer, Power Towers Ltd (The Company), undertakes to replace or repair, free of charge, any defective part/component, which the company considers to be due to faulty workmanship or material within 18 months of the sale date, except for:

The telescopic mast is a sealed unit. If the mast is opened in any way warranty may be invalid.

Defects arising from neglect, misuse or unauthorised modifications.

Damage caused by abuse, misuse, dropping or other similar damage caused by or as a result of failure to follow transportation, storage, installation, loading or operation instructions.

Alterations, additions or repairs carried out by persons other than the Manufacturer or their recognised distributors.

Transportation or shipment costs to and from the Manufacturer or their recognised agents, for repair or assessment against a warranty claim, on any Ecolift or component.

Materials and/or labour costs to renew, repair or replace components due to fair wear and tear.

Faults arising from the use of non-standard or additional parts, or any consequential damage or wear caused by the fitting or use of such parts.

Important

Warranty may, at the sole discretion of the Manufacturer, be voided if the scheduled service/inspections are not carried out in accordance with this manual.

The Manufacturer and/or their recognised agents, directors, employees or insurers will not be held liable for consequential or other damages, losses or expenses in connection with or by reason of or the inability to use the Ecolift for any purpose.

Modifications

If additional equipment or any third party work, modifications or alterations are to be carried out on the Ecolift which will involve any welding, drilling or any form of cutting or distortion of materials, full written approval must be obtained from the Manufacturer prior to the work being carried out.

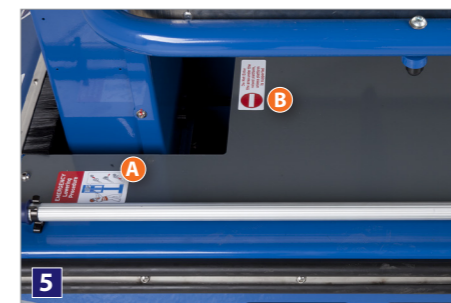

Picture	Description	Decal Location
1.	A. 15kg Maximum load	Inside toolbox, front face
2.	A. Do not tie down over guardrails	Each side of cage, middle and lower guardrail
	B. Product logo, x 2	Left hand and right hand side of platform tray
3.	A. 234 kg Max wheel/castor load, x 4	Left and right hand side of chassis - 2 each side, position appropriate label according to wheel/label colour
	Note: Use 245 kg Max wheel/castor load for Wind Rated machine. (Labels are on same sheet).	
	B. Fork lift point x 2	Left and right hand side - 1 each side centre of chassis between forklift loading pockets
4.	A. Spirit Level Guidance	Left hand side of spirit level, on chassis cover
5.	A. Emergency lowering procedure	Chassis cover, left hand side of mast
	B. Do not enter the area underneath a raised platform unless it is supported	Centre of chassis cover, front of mast
6.	A. Hand trap point	Chassis, directly opposite bottom of mast
	B. Lifting/tie down point x 2	Each corner of chassis next to lifting/tie down points
7.	A. Operating Instructions	Left hand gate, upper panel.
	B. Use advisory label	Right hand gate, upper panel
	C. 150kg SWL	Left hand gate, lower panel
8.	A. Horizontal pull force max 200 N	Middle of mast, internal face
	B. Safety Guidelines	Middle of mast, internal face
	C. Harness point, fall restraint only	Middle of mast, internal face



Picture	Description	Decal Location
8.	A. Horizontal pull force max 200 N	Middle of mast, internal face
	B. Safety Requirements	Middle of mast, internal face
	C. Harness Point	Lower mast, internal face, above hook
9.	A. Elevate	Centre of flywheel
10.	A. Spec Plate	Bottom, external face of mast

OPERATING SPECIFICATIONS FOR ECOLIFT WIND RATED

Working Dimensions

Maximum working height:	4.20 m
Maximum platform height:	2.20 m
Platform dimensions:	850 mm (L) x 644 mm (W)
Working footprint:	1280 mm x 950 mm
Safe working load:	150 kg (1 person + tools)
Maximum manual force:	200 N
Maximum gradient for operation:	3 degrees
Maximum wind force:	Internal/External, 12.5 m/s
Maximum wheel force	245 kg (2.4 kN)
Maximum castor point load:	245 kg (2.4 kN)
Sound pressure level:	Less than 70dBA

Closed Dimensions

Length:	1.28 m
Width:	0.95 m
Height:	1.55 m
Weight:	340 kg

Lift Cycles

Unlimited, subject to maintenance program being adhered to.



Ecolift Wind Rated is operable on gradients up to 3° and in winds up to 12.5m/s

Only trained, authorised operators should use this platform. All operators must read and comply with the following Operating Instructions and Safety Guidelines before using the Ecolift Wind Rated (WR). This platform is designed for safe access to a maximum working height of 4.2m for 1 person + tools (150kg safe working load) and is for indoor or outdoor use.

Operating Instructions

1. This platform is for indoor or outdoor use.
2. Ensure floor is level up to a 3° slope and able to support the total combined maximum load (150kg safe working load) and machine weight (340kg) of 490kg total. The maximum wheel load is 245kg (2.4kN).

Pre-Operation Checks:

1. Visually inspect machine; check for signs of damage to structure including castors, wheels, operating handle.
2. Position machine safely; ensure there are no overhead obstructions or dangers.
3. Ensure ground conditions are suitable. The machine should be used on hard, level surfaces up to 3° that will support machine and safe working load.
4. Ensure castors are locked before entering platform.
5. Check operating handle is working correctly by stepping into basket through gates, ensure gates are fully closed behind you; gently pull handle knob towards you, release: handle knob should spring back to prevent handle turning. Do not use machine if handle knob is damaged or sticking.
6. Cordon off work area in accordance with guidelines.
7. Safe working load for the Ecolift WR is 1 person only plus tools with a total of 150kg including person. Never exceed the safe working load.

Standard Operation:

1. The Ecolift WR must only be used on hard surfaces not sloping more than 3°. Ensure a person is available at ground level to assist in case of emergency.
2. Position machine under application. Check for any overhead obstructions or dangers.
3. Check spirit level on machine chassis to ensure machine is level up to 3°. Do not use machine unless bubble remains within 3° circle.
4. To use the Ecolift WR, step into platform through gates. Ensure gates are fully closed behind you. Gently pull operating handle knob towards you; turn handle clockwise to elevate. Always check for overhead obstructions or dangers. To stop elevation: stop turning handle; release handle knob. Turn handle anti-clockwise (counter-clockwise) to descend.

Never attempt to move the Ecolift WR when elevated

Emergency Operation:

In the event of having to recover an operator who is incapacitated:

1. Remove emergency operation tool located on chassis.
2. Follow instructions on Emergency Lowering Procedure instruction label.
3. Allow platform to descend to the fully lowered position.

Do

1. Read and adhere to the instructions both on the machine and in this Instruction Guide.
2. Ensure pre-operation checks and operations are carried out in the manner described.
3. Use only on hard, level surfaces up to 3° able to support the weight of the machine.
4. Ensure operator is fit and does not suffer from fear of heights.
5. Ensure guardrail gates are closed before elevation.
6. Ensure work area around the machine is cordoned off from pedestrians and other traffic.
7. Ensure operator is wearing the correct safety equipment.
8. Ensure the platform is correctly positioned so as not to come into contact with fixed or moving objects.
9. Ensure that the safe working load is evenly distributed in the platform.
10. Ensure the machine is being operated within the PUWER (Provision and Use of Workplace Equipment Regulations).
11. Ensure the castor brakes are applied when leaving the machine unattended

Don't

1. Never exceed the safe working load (150kg).
2. Never use the Ecolift WR as a goods lift or crane.
3. Never exceed horizontal forces; never use in wind exceeding 12.5m/sec.
4. Never use in the vicinity of live conductors.
5. Never try to move the Ecolift WR on its wheels when elevated.
6. Never extend the height of the platform by using boxes, steps, ladders etc.
7. Never modify the Ecolift WR in any way without the full approval of the manufacturer.
8. Never attempt to enter or exit the platform unless it is fully lowered.
9. Never lift heavy components of the Ecolift without the use of the correct lifting equipment.
10. Never use the Ecolift in an explosive environment.
11. Never use the machine if you are fatigued.
12. Never use the machine inappropriately or for "horseplay."
13. Never use the machine if under the influence of drugs or alcohol.
14. Never use the machine if suffering from poor health or using medication which might impair the safe operation of the Ecolift.
15. Never use the Ecolift if vision impaired by bright lighting.
16. Never push the Ecolift on sloping surfaces without the use of a safe method.
17. Never push or pull objects with the platform.
18. Never use on surfaces over a 3° gradient.

WHEELS AND CASTORS

It is absolutely essential that the wheels and castors are maintained in good condition at all times, for two reasons:

The first is that they act as the stabilisers, and whilst their load capacity is over rated for the application, any failure could result in a serious accident. Secondly, if the bearings become tight, then it will make the machine difficult to manoeuvre.

A measure of horizontal push force can simply be made to determine the condition of the wheel bearings. On a flat smooth surface the machine should move with a force of 9 – 10 kgs at the mid guard rail height. The maximum allowance is 20 kgs. Obviously this force is dependant upon the surface and gradient, but the above is the recognised method of measurement, in accordance with HSE guidelines.

Check rear wheels to ensure retention circlip is securely fitted and undamaged.

When replacing components for any reason, only use OEM specification parts, either supplied from the manufacturer or authorised in writing by the manufacturer. Warranties and design approvals will be void if alternative components are fitted. It is essential to obtain manufacturer's approval of any alteration which might affect stability, strength or performance in writing before proceeding.

MACHINES WITH ATEX CERTIFICATION

The Ecolift, standard or windrated, can be specified as ATEX approved, for zones 1 and 21. This comes with third party approval by SGS Baseefa (Certificate no. Baseefa 13ATEX0150X).

There are no elements of the machine which were identified as a potential hazard.

There are no specific additional maintenance procedures required for the ATEX certified Ecolift.



www.powertowers.com



100% British designed
and manufactured.