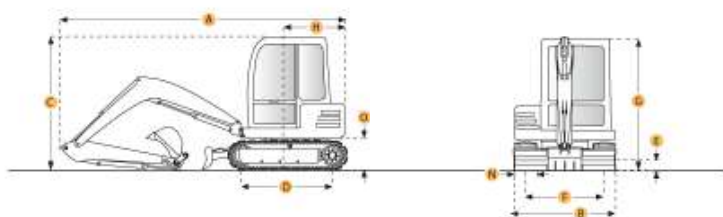

JCB 8015 MINI EXCAVATOR

Boom/Stick Option Boom/Stick Option (HEX) 1 ▾

A. SHIPPING LENGTH OF UNIT	10.9 ft in	3346 mm
C. SHIPPING HEIGHT OF UNIT	7.6 ft in	2318 mm
I. MAX CUTTING HEIGHT	11.2 ft in	3393 mm
J. MAX LOADING HEIGHT	8.3 ft in	2501 mm
K. MAX REACH ALONG GROUND	12.3 ft in	3764 mm
L. MAX VERTICAL WALL DIGGING DEPTH	5.4 ft in	1659 mm
M. MAX DIGGING DEPTH	6.7 ft in	2044 mm

Dimensions

B. WIDTH TO OUTSIDE OF TRACKS	3.2 ft in	972 mm
D. LENGTH OF TRACK ON GROUND	3.7 ft in	1127 mm
E. GROUND CLEARANCE	0.6 ft in	158 mm
G. HEIGHT TO TOP OF CAB	7.6 ft in	2318 mm
H. TAIL SWING RADIUS	3.3 ft in	1028 mm
O. COUNTERWEIGHT CLEARANCE	1.3 ft in	376 mm

Undercarriage

F. TRACK GAUGE	2.4 ft in	742 mm
----------------	-----------	--------

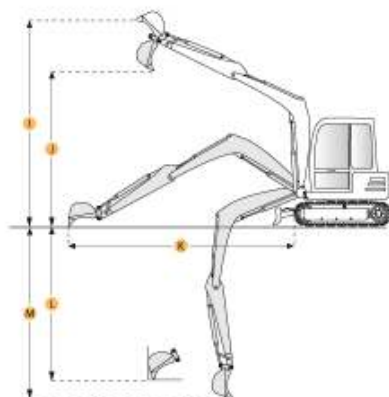

RITCHIE Specs Everything about Equipment

JCB 8015 MINI EXCAVATOR

Specification

Engine

MODEL	403C-11	
GROSS POWER	19.7 hp	14.7 kw
NET POWER	19 hp	14.2 kw
DISPLACEMENT	69 cu in	1.1 L
MAX TORQUE	45.7 lb ft	62 Nm

Operational

OPERATING WEIGHT	3505 lb	1590 kg
FUEL CAPACITY	6.2 gal	23.5 L
COOLING SYSTEM FLUID CAPACITY	1.3 gal	5 L
HYDRAULIC SYSTEM FLUID CAPACITY	7.4 gal	28 L
ENGINE OIL CAPACITY	1.1 gal	4 L
OPERATING VOLTAGE	12 V	
ALTERNATOR SUPPLIED AMPERAGE	40 amps	
HYDRAULIC SYSTEM RELIEF VALVE PRESSURE	3336 psi	23000.9 kPa
HYDRAULIC PUMP FLOW CAPACITY	7.1 gal/min	26.9 L/min

Swing Mechanism

SWING SPEED	10 rpm	
-------------	--------	--

Undercarriage

MAX TRAVEL SPEED	2.4 mph	3.8 km/h
TRACK GAUGE	2.4 ft in	742 mm

Boom/Stick Option (HEX) 1

BOOM/STICK OPTION (HEX) 1	Arm Length 3ft.10in. (1161mm)	
SHIPPING HEIGHT OF UNIT	7.6 ft in	2318 mm
SHIPPING LENGTH OF UNIT	10.9 ft in	3346 mm
MAX DIGGING DEPTH	6.7 ft in	2044 mm
MAX REACH ALONG GROUND	12.3 ft in	3764 mm
MAX CUTTING HEIGHT	11.2 ft in	3393 mm
MAX LOADING HEIGHT	8.3 ft in	2501 mm
MAX VERTICAL WALL DIGGING DEPTH	5.4 ft in	1659 mm

Boom/Stick Option (HEX) 2

BOOM/STICK OPTION (HEX) 2	Arm Length 4ft.2in. (1261mm)	
SHIPPING HEIGHT OF UNIT	7.5 ft in	2304 mm
SHIPPING LENGTH OF UNIT	10.7 ft in	3261 mm
MAX DIGGING DEPTH	7 ft in	2144 mm
MAX REACH ALONG GROUND	12.6 ft in	3847 mm
MAX CUTTING HEIGHT	11.3 ft in	3454 mm
MAX LOADING HEIGHT	8.4 ft in	2559 mm
MAX VERTICAL WALL DIGGING DEPTH	5.8 ft in	1754 mm

Dimensions

WIDTH TO OUTSIDE OF TRACKS	3.2 ft in	972 mm
HEIGHT TO TOP OF CAB	7.6 ft in	2318 mm
GROUND CLEARANCE	0.6 ft in	158 mm
COUNTERWEIGHT CLEARANCE	1.3 ft in	376 mm
TAIL SWING RADIUS	3.3 ft in	1028 mm
LENGTH OF TRACK ON GROUND	3.7 ft in	1127 mm

