

BOM

Item	Description	Quantity
1	Dual Locking Castors	4
2	500mm Adjustable Leg	4
3	2 Rung 1m Ladder Frame	0
4	2 Rung 1m Span Frame	0
5	3 Rung 1.5m Ladder Frame	0
6	3 Rung 1.5m Span Frame	0
7	4 Rung 2m Ladder Frame	2
8	4 Rung 2m Span Frame	2
9	Trap Door Platform	2
10	Standard Platform	1
11	Horizontal Brace (red trigger)	10
12	Diagonal Brace (blue trigger)	5
13	(New style) Complete Toe-board Set	1
14	Standard Stabiliser	4
15	Jumbo Stabiliser	0
16	Instruction Manual & BSEN1004 certificate of conformity	1

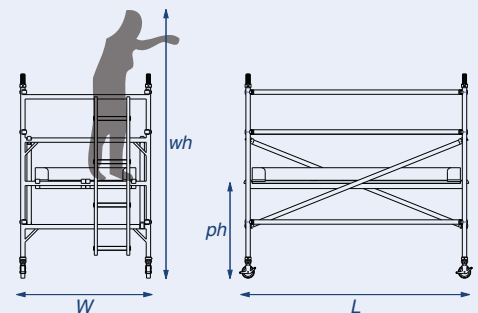

Technical Information

Base Dimensions: (L)1.8m X (W)1.45m

Maximum Platform Height (ph): 3.2m

Maximum Working Height (wh): 5.2m

Maximum Working Load Per Platform: 275kg

Maximum Working Load Per Tower:
(including tower weight) 950kg

Weight: 159kg