

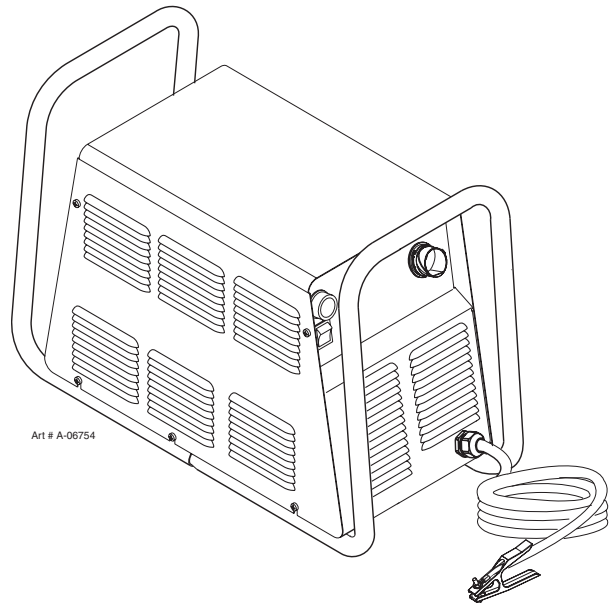

**101**

# **CUTMASTER™**

## **PLASMA CUTTING SYSTEM**



# **Operating Manual**

Rev. AB.01

Date: March 14, 2007

Manual # 0-2852

Operating Features:

**80**  
AMP

**DC**

**1**  
PHASE

**3**  
PHASE

**208-  
230**  
V

**400**  
V

**460**  
V

**600**  
V



## **WE APPRECIATE YOUR BUSINESS!**

Congratulations on your new Thermal Dynamics product. We are proud to have you as our customer and will strive to provide you with the best service and reliability in the industry. This product is backed by our extensive warranty and world-wide service network. To locate your nearest distributor or service agency call 1-800-426-1888, or visit us on the web at [www.thermal-dynamics.com](http://www.thermal-dynamics.com).

This Operating Manual has been designed to instruct you on the correct use and operation of your Thermal Dynamics product. Your satisfaction with this product and its safe operation is our ultimate concern. Therefore please take the time to read the entire manual, especially the Safety Precautions. They will help you to avoid potential hazards that may exist when working with this product.

## **YOU ARE IN GOOD COMPANY!**

**The Brand of Choice for Contractors and Fabricators Worldwide.**

Thermal Dynamics is a Global Brand of manual and automation Plasma Cutting Products for Thermadyne Industries Inc.

We distinguish ourselves from our competition through market-leading, dependable products that have stood the test of time. We pride ourselves on technical innovation, competitive prices, excellent delivery, superior customer service and technical support, together with excellence in sales and marketing expertise.

Above all, we are committed to developing technologically advanced products to achieve a safer working environment within the welding industry.



---

*Read and understand this entire Manual and your employer's safety practices before installing, operating, or servicing the equipment.*

*While the information contained in this Manual represents the Manufacturer's best judgement, the Manufacturer assumes no liability for its use.*

---

Plasma Cutting Power Supply  
CutMaster™ 101  
Operating Manual Number 0-2852

Covered under U.S. Patents

Published by:  
Thermal Dynamics Corporation  
82 Benning Street  
West Lebanon, New Hampshire, USA 03784  
(603) 298-5711

[www.thermal-dynamics.com](http://www.thermal-dynamics.com)

© Copyright 2003, 2004, 2005, 2006, 2007 by  
Thermal Dynamics Corporation

All rights reserved.

Reproduction of this work, in whole or in part, without written permission of the publisher is prohibited.

The publisher does not assume and hereby disclaims any liability to any party for any loss or damage caused by any error or omission in this Manual, whether such error results from negligence, accident, or any other cause.

Printed in the United States of America

Publication Date: March 14, 2007

**Record the following information for Warranty purposes:**

Where Purchased: \_\_\_\_\_

Purchase Date: \_\_\_\_\_

Power Supply Serial #: \_\_\_\_\_

Torch Serial #: \_\_\_\_\_

# TABLE OF CONTENTS

SECTION 1:	
GENERAL INFORMATION .....	1-1
1.01 Notes, Cautions and Warnings .....	1-1
1.02 Important Safety Precautions .....	1-1
1.03 Publications .....	1-2
1.04 Declaration of Conformity .....	1-4
1.05 Statement of Warranty .....	1-5
SECTION 2:	
INTRODUCTION .....	2-1
2.01 Scope of Manual .....	2-1
2.02 Power Supply Specifications .....	2-1
2.03 Input Wiring Specifications .....	2-2
2.04 Power Supply Features .....	2-3
2.05 Power Supply Options and Accessories .....	2-4
SECTION 3: INSTALLATION .....	3-1
3.01 Unpacking .....	3-1
3.02 Lifting Options .....	3-1
3.03 Primary Input Power Connections .....	3-2
3.04 Gas Connections .....	3-4
3.05 Torch Connections .....	3-8
SECTION 4: OPERATION .....	4-1
4.01 Product Features .....	4-1
4.02 Preparations For Operating .....	4-2
SECTION 5:	
SERVICE .....	5-1
5.01 General Maintenance .....	5-1
5.02 Common Faults .....	5-5
5.03 Basic Troubleshooting Guide .....	5-6
5.04 Power Supply Basic Parts Replacement .....	5-11
SECTION 6:	
PARTS LISTS .....	6-1
6.01 Introduction .....	6-1
6.02 Ordering Information .....	6-1
6.03 Power Supply Replacement .....	6-1
6.04 Replacement Parts .....	6-2
6.05 Options and Accessories .....	6-2
6.06 Torch Parts .....	6-3

## TABLE OF CONTENTS (continued)

PATENT INFORMATION .....	6-4
APPENDIX 1: SEQUENCE OF OPERATION (BLOCK DIAGRAM) .....	A-1
APPENDIX 2: DATA TAG INFORMATION .....	A-2
APPENDIX 3: MAINTENANCE SCHEDULE .....	A-3
APPENDIX 4: TORCH PIN - OUT DIAGRAMS .....	A-4
APPENDIX 5: CONNECTION DIAGRAMS .....	A-5
APPENDIX 6: SYSTEM SCHEMATIC, 208/230V UNITS .....	A-6
APPENDIX 7: SYSTEM SCHEMATIC, 400-460V UNITS .....	A-8
APPENDIX 8: SYSTEM SCHEMATIC, 600V UNITS .....	A-10
APPENDIX 9: Publication History .....	A-12
Global Customer Service Contact Information .....	Inside Rear Cover



# SECTION 1: GENERAL INFORMATION

## 1.01 Notes, Cautions and Warnings

Throughout this manual, notes, cautions, and warnings are used to highlight important information. These highlights are categorized as follows:

### NOTE

*An operation, procedure, or background information which requires additional emphasis or is helpful in efficient operation of the system.*

### CAUTION

*A procedure which, if not properly followed, may cause damage to the equipment.*



### WARNING

*A procedure which, if not properly followed, may cause injury to the operator or others in the operating area.*

## 1.02 Important Safety Precautions



### WARNINGS

**OPERATION AND MAINTENANCE OF PLASMA ARC EQUIPMENT CAN BE DANGEROUS AND HAZARDOUS TO YOUR HEALTH.**

*Plasma arc cutting produces intense electric and magnetic emissions that may interfere with the proper function of cardiac pacemakers, hearing aids, or other electronic health equipment. Persons who work near plasma arc cutting applications should consult their medical health professional and the manufacturer of the health equipment to determine whether a hazard exists.*

*To prevent possible injury, read, understand and follow all warnings, safety precautions and instructions before using the equipment. Call 1-603-298-5711 or your local distributor if you have any questions.*



### GASES AND FUMES

Gases and fumes produced during the plasma cutting process can be dangerous and hazardous to your health.

- Keep all fumes and gases from the breathing area. Keep your head out of the welding fume plume.
- Use an air-supplied respirator if ventilation is not adequate to remove all fumes and gases.
- The kinds of fumes and gases from the plasma arc depend on the kind of metal being used, coatings on the metal, and the different processes. You must be very careful when cutting or welding any metals which may contain one or more of the following:

Antimony	Chromium	Mercury
Arsenic	Cobalt	Nickel
Barium	Copper	Selenium
Beryllium	Lead	Silver
Cadmium	Manganese	Vanadium

- Always read the Material Safety Data Sheets (MSDS) that should be supplied with the material you are using. These MSDSs will give you the information regarding the kind and amount of fumes and gases that may be dangerous to your health.
- For information on how to test for fumes and gases in your workplace, refer to item 1 in Subsection 1.03, Publications in this manual.
- Use special equipment, such as water or down draft cutting tables, to capture fumes and gases.
- Do not use the plasma torch in an area where combustible or explosive gases or materials are located.
- Phosgene, a toxic gas, is generated from the vapors of chlorinated solvents and cleansers. Remove all sources of these vapors.
- This product, when used for welding or cutting, produces fumes or gases which contain chemicals known to the State of California to cause birth defects and, in some cases, cancer. (California Health & Safety Code Sec. 25249.5 et seq.)



### ELECTRIC SHOCK

Electric Shock can injure or kill. The plasma arc process uses and produces high voltage electrical energy. This electric energy can cause severe or fatal shock to the operator or others in the workplace.

- Never touch any parts that are electrically "live" or "hot."

- Wear dry gloves and clothing. Insulate yourself from the work piece or other parts of the welding circuit.
- Repair or replace all worn or damaged parts.
- Extra care must be taken when the workplace is moist or damp.
- Install and maintain equipment according to NEC code, refer to item 9 in Subsection 1.03, Publications.
- Disconnect power source before performing any service or repairs.
- Read and follow all the instructions in the Operating Manual.



### FIRE AND EXPLOSION

Fire and explosion can be caused by hot slag, sparks, or the plasma arc.

- Be sure there is no combustible or flammable material in the workplace. Any material that cannot be removed must be protected.
- Ventilate all flammable or explosive vapors from the workplace.
- Do not cut or weld on containers that may have held combustibles.
- Provide a fire watch when working in an area where fire hazards may exist.
- Hydrogen gas may be formed and trapped under aluminum workpieces when they are cut underwater or while using a water table. **DO NOT** cut aluminum alloys underwater or on a water table unless the hydrogen gas can be eliminated or dissipated. Trapped hydrogen gas that is ignited will cause an explosion.



### NOISE

Noise can cause permanent hearing loss. Plasma arc processes can cause noise levels to exceed safe limits. You must protect your ears from loud noise to prevent permanent loss of hearing.

- To protect your hearing from loud noise, wear protective ear plugs and/or ear muffs. Protect others in the workplace.
- Noise levels should be measured to be sure the decibels (sound) do not exceed safe levels.
- For information on how to test for noise, see item 1 in Subsection 1.03, Publications, in this manual.



### PLASMA ARC RAYS

Plasma Arc Rays can injure your eyes and burn your skin. The plasma arc process produces very bright ultra violet and infra red light. These arc rays will damage your eyes and burn your skin if you are not properly protected.

- To protect your eyes, always wear a welding helmet or shield. Also always wear safety glasses with side shields, goggles or other protective eye wear.
- Wear welding gloves and suitable clothing to protect your skin from the arc rays and sparks.
- Keep helmet and safety glasses in good condition. Replace lenses when cracked, chipped or dirty.
- Protect others in the work area from the arc rays. Use protective booths, screens or shields.
- Use the shade of lens as suggested in the following per ANSI/ASC Z49.1:

Arc Current	Minimum Protective Shade No.	Suggested Shade No.
Less Than 300*	8	9
300 - 400*	9	12
400 - 800*	10	14

\* These values apply where the actual arc is clearly seen. Experience has shown that lighter filters may be used when the arc is hidden by the workpiece.

## 1.03 Publications

Refer to the following standards or their latest revisions for more information:

1. OSHA, SAFETY AND HEALTH STANDARDS, 29CFR 1910, obtainable from the Superintendent of Documents, U.S. Government Printing Office, Washington, D.C. 20402
2. ANSI Standard Z49.1, SAFETY IN WELDING AND CUTTING, obtainable from the American Welding Society, 550 N.W. LeJeune Rd, Miami, FL 33126
3. NIOSH, SAFETY AND HEALTH IN ARC WELDING AND GAS WELDING AND CUTTING, obtainable from the Superintendent of Documents, U.S. Government Printing Office, Washington, D.C. 20402
4. ANSI Standard Z87.1, SAFE PRACTICES FOR OCCUPATION AND EDUCATIONAL EYE AND FACE PROTECTION, obtainable from American National Standards Institute, 1430 Broadway, New York, NY 10018
5. ANSI Standard Z41.1, STANDARD FOR MEN'S SAFETY-TOE FOOTWEAR, obtainable from the American National Standards Institute, 1430 Broadway, New York, NY 10018



6. ANSI Standard Z49.2, FIRE PREVENTION IN THE USE OF CUTTING AND WELDING PROCESSES, obtainable from American National Standards Institute, 1430 Broadway, New York, NY 10018
7. AWS Standard A6.0, WELDING AND CUTTING CONTAINERS WHICH HAVE HELD COMBUSTIBLES, obtainable from American Welding Society, 550 N.W. LeJeune Rd, Miami, FL 33126
8. NFPA Standard 51, OXYGEN-FUEL GAS SYSTEMS FOR WELDING, CUTTING AND ALLIED PROCESSES, obtainable from the National Fire Protection Association, Batterymarch Park, Quincy, MA 02269
9. NFPA Standard 70, NATIONAL ELECTRICAL CODE, obtainable from the National Fire Protection Association, Batterymarch Park, Quincy, MA 02269
10. NFPA Standard 51B, CUTTING AND WELDING PROCESSES, obtainable from the National Fire Protection Association, Batterymarch Park, Quincy, MA 02269
11. CGA Pamphlet P-1, SAFE HANDLING OF COMPRESSED GASES IN CYLINDERS, obtainable from the Compressed Gas Association, 1235 Jefferson Davis Highway, Suite 501, Arlington, VA 22202
12. CSA Standard W117.2, CODE FOR SAFETY IN WELDING AND CUTTING, obtainable from the Canadian Standards Association, Standards Sales, 178 Rexdale Boulevard, Rexdale, Ontario, Canada M9W 1R3
13. NWSA booklet, WELDING SAFETY BIBLIOGRAPHY obtainable from the National Welding Supply Association, 1900 Arch Street, Philadelphia, PA 19103
14. American Welding Society Standard AWSF4.1, RECOMMENDED SAFE PRACTICES FOR THE PREPARATION FOR WELDING AND CUTTING OF CONTAINERS AND PIPING THAT HAVE HELD HAZARDOUS SUBSTANCES, obtainable from the American Welding Society, 550 N.W. LeJeune Rd, Miami, FL 33126
15. ANSI Standard Z88.2, PRACTICE FOR RESPIRATORY PROTECTION, obtainable from American National Standards Institute, 1430 Broadway, New York, NY 10018

## 1.04 Declaration of Conformity

Manufacturer: Thermal Dynamics Corporation  
Address: 82 Benning Street  
West Lebanon, New Hampshire 03784  
USA

The equipment described in this manual conforms to all applicable aspects and regulations of the 'Low Voltage Directive' (European Council Directive 73/23/EEC as amended by Council Directive 93/68/EEC) and to the National legislation for the enforcement of this Directive.

Serial numbers are unique with each individual piece of equipment and details description, parts used to manufacture a unit and date of manufacture.

### National Standard and Technical Specifications

The product is designed and manufactured to a number of standards and technical requirements. Among them are:

- \* CSA (Canadian Standards Association) standard C22.2 number 60 for Arc welding equipment.
- \* UL (Underwriters Laboratory) rating 94VO flammability testing for all printed-circuit boards used.
- \* ISO/IEC 60974-1 (BS 638-PT10) (EN 60 974-1) (EN50192) (EN50078) applicable to plasma cutting equipment and associated accessories.
- \* Extensive product design verification is conducted at the manufacturing facility as part of the routine design and manufacturing process. This is to ensure the product is safe, when used according to instructions in this manual and related industry standards, and performs as specified. Rigorous testing is incorporated into the manufacturing process to ensure the manufactured product meets or exceeds all design specifications.

Thermal Dynamics has been manufacturing products for more than 30 years, and will continue to achieve excellence in our area of manufacture.

Manufacturers responsible representative: Giorgio Bassi  
Managing Director  
Thermal Dynamics Europe  
Via rio Fabbiani 8A  
40067 Rastignano (BO)  
Italy

## 1.05 Statement of Warranty

**LIMITED WARRANTY:** Subject to the terms and conditions established below, Thermal Dynamics® Corporation warrants to the original retail purchaser that new Thermal Dynamics CUTMASTER™ 1Series plasma cutting systems sold after the effective date of this warranty are free of defects in material and workmanship. Should any failure to conform to this warranty appear within the applicable period stated below, Thermal Dynamics Corporation shall, upon notification thereof and substantiation that the product has been stored operated and maintained in accordance with Thermal Dynamics' specifications, instructions, recommendations and recognized industry practice, correct such defects by suitable repair or replacement.

**This warranty is exclusive and in lieu of any warranty of merchantability or fitness for a particular purpose.**

Thermal Dynamics will repair or replace, at its discretion, any warranted parts or components that fail due to defects in material or workmanship within the time periods set out below. Thermal Dynamics Corporation must be notified within 30 days of any failure, at which time Thermal Dynamics Corporation will provide instructions on the warranty procedures to be implemented.

Thermal Dynamics Corporation will honor warranty claims submitted within the warranty periods listed below. All warranty periods begin on the date of sale of the product to the original retail customer or 1 year after sale to an authorized Thermal Dynamics Distributor.

### LIMITED WARRANTY PERIOD

Product	Power Supply Components (Parts and Labor)	Torch and Leads (Parts and Labor)
CUTMASTER™ 51	3 Years	1 Year
CUTMASTER™ 81	3 Years	1 Year
CUTMASTER™ 101	3 Years	1 Year
CUTMASTER™ 151	3 Years	1 Year

This warranty does not apply to:

1. Consumable Parts, such as tips, electrodes, shield cups, o - rings, starter cartridges, gas distributors, fuses, filters.
2. Equipment that has been modified by an unauthorized party, improperly installed, improperly operated or misused based upon industry standards.

In the event of a claim under this warranty, the remedies shall be, at the discretion of Thermal Dynamics Corporation:

1. Repair of the defective product.
2. Replacement of the defective product.
3. Reimbursement of reasonable costs of repair when authorized in advance by Thermal Dynamics.
4. Payment of credit up to the purchase price less reasonable depreciation based on actual use.

These remedies may be authorized by Thermal Dynamics and are FOB West Lebanon, NH or an authorized Thermadyne service station. Product returned for service is at the owner's expense and no reimbursement of travel or transportation is authorized.

**LIMITATION OF LIABILITY:** Thermal Dynamics Corporation shall not under any circumstances be liable for special or consequential damages such as, but not limited to, damage or loss of purchased or replacement goods or claims of customer or distributors (hereinafter "Purchaser") for service interruption. The remedies of the Purchaser set forth herein are exclusive and the liability of Thermal Dynamics with respect to any contract, or anything done in connection therewith such as the performance or breach thereof, or from the manufacture, sale, delivery, resale, or use of the goods covered by or furnished by Thermal Dynamics whether arising out of contract, negligence, strict tort, or under any warranty, or otherwise, shall not, except as expressly provided herein, exceed the price of the goods upon which liability is based.

**This warranty becomes invalid if replacement parts or accessories are used which may impair the safety or performance of any Thermal Dynamics product.**

**This warranty is invalid if the Thermal Dynamics product is sold by non - authorized persons.**

Effective January 15, 2004

This Page Intentionally Blank

# SECTION 2: INTRODUCTION

---

## 2.01 Scope of Manual

This manual contains descriptions, operating instructions and basic maintenance procedures for the Thermal Dynamics CutMaster 101 Plasma Cutting Power Supply only. Servicing of this equipment is restricted to properly trained personnel; unqualified personnel are strictly cautioned against attempting repairs or adjustments not covered in this manual, at the risk of voiding the Warranty.

Read this manual thoroughly. A complete understanding of the characteristics and capabilities of this equipment will assure the dependable operation for which it was designed.

### NOTE

*Refer to the Torch Manual for torch and cutting information.*

## 2.02 Power Supply Specifications

<b>CutMaster 101 Power Supply Specifications</b>							
Input Power	208 / 230 VAC (187 - 253 VAC), Single Phase, 50/60 Hz						
	400 VAC (360 - 440 VAC), Three Phase, 50/60 Hz						
	460 VAC (414 - 506 VAC), Single Phase, 60 Hz						
	460 VAC (414 - 506 VAC), Three Phase, 60 Hz						
	600 VAC (517 - 632 VAC), Three Phase, 60 Hz						
Input Power Cable	Cable for 208/230 VAC unit includes plug.						
Output Current	20 - 80 Amps, Continuously Adjustable						
Power Supply Gas Filtering Ability	Particulates to 20 Microns						
<b>CutMaster 101 Power Supply Duty Cycle *</b>							
Ambient Temperature	40° C (104° F)						
		IEC Rating	TDC Rating	IEC Rating	TDC Rating	IEC Rating	TDC Rating
<b>208/230V and 460V Units</b>	Duty Cycle	<b>40%</b>		<b>60%</b>		<b>100%</b>	
	Current	80A	78A	68A	68A	45A	45A
	DC Voltage	112V	120V	107V	111V	98V	98V
<b>400V Units</b>	Duty Cycle	<b>35%</b>		<b>60%</b>		<b>100%</b>	
	Current	80A	n/a	68A	n/a	45A	n/a
	DC Voltage	112V	n/a	107V	n/a	98V	n/a
<b>600V Units</b>	Duty Cycle	<b>35%</b>		<b>60%</b>		<b>100%</b>	
	Current	80A	78A	68A	68A	43A	43A
	DC Voltage	112V	120V	107V	111V	97V	97V
* NOTE: The duty cycle will be reduced if the primary input power (AC) is low or the output voltage (DC) is higher than shown in this chart.							

### NOTE:

*IEC Rating is determined as specified by the International Electro-Technical Commission. These specifications include calculating an output voltage based upon power supply rated current. To facilitate comparison between power supplies, all manufacturers use this output voltage to determine duty cycle.*

*TDC Rating is determined using an output voltage representative of actual output voltage during cutting with a TDC torch. This voltage may be more or less than IEC voltage, depending upon choice of torch, consumables, and actual cutting operation.*

## Power Supply Dimensions & Weight

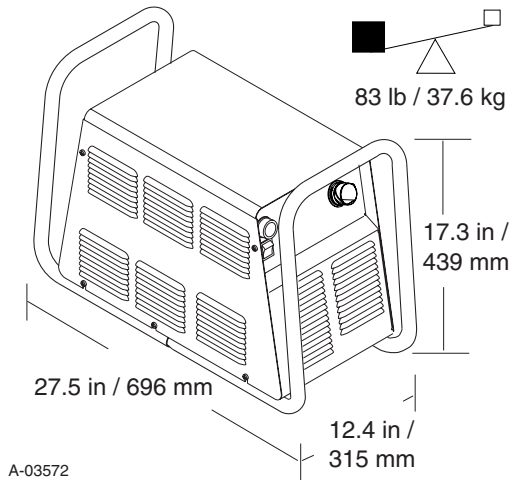

## Ventilation Clearance Requirements

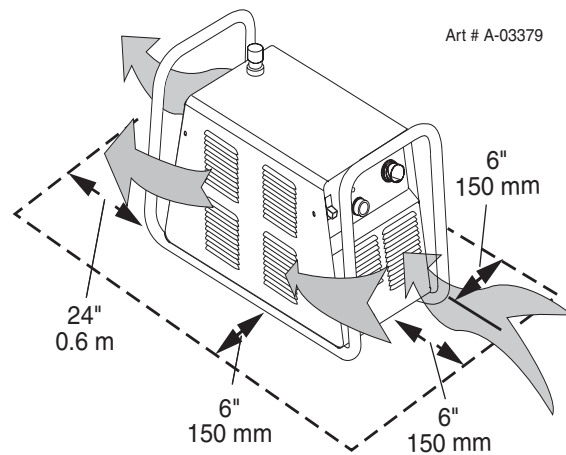

## 2.03 Input Wiring Specifications

CutMaster 101 Input Wiring Specifications											
Input		Power Input		Current Input		Suggested Sizes (See Notes)					
Voltage (Volts)	Freq. (Hz)	1-Ph (kVA)	3-Ph (kVA)	1-Ph (Amps)	3-Ph (Amps)	Fuse (Amps)		Wire (AWG)		Wire (Canada)	
						1-Ph	3-Ph	1-Ph	3-Ph	1-Ph	3-Ph
208	50	14.4		69		90		6		6	
208	60	15.6		75		90		6		6	
230	50	15		65		80		6		6	
230	60	15.5		67		80		6		6	
400	50/60		13.9		20		30		10		10
460	60	18		39		50		10		10	
460	60		16		20		30		12		12
600	60		13.5		13		20		12		12

Line Voltages with Suggested Circuit Protection and Wire Sizes  
Based on National Electric Code and Canadian Electrical Code

### NOTES

Refer to Local and National Codes or local authority having jurisdiction for proper wiring requirements.

Cable size is de-rated based on the Duty Cycle of the equipment.

The suggested sizes are based on flexible power cable with power plug installations. For hard-wired installations refer to local or national codes.

Cable conductor temperature used is 167° F (75° C).

An energy limiting fuse UL Class RK-1 (examples: BUSS LPS /LPN-RK or Gould-Shawmut AZK-A6K) should be used to minimize damage to Plasma Cutting, Welding or power distribution equipment.

**NEVER** use replaceable element fuses like UL Class H, or "one-time" fuses like UL Class K5.

## 2.04 Power Supply Features

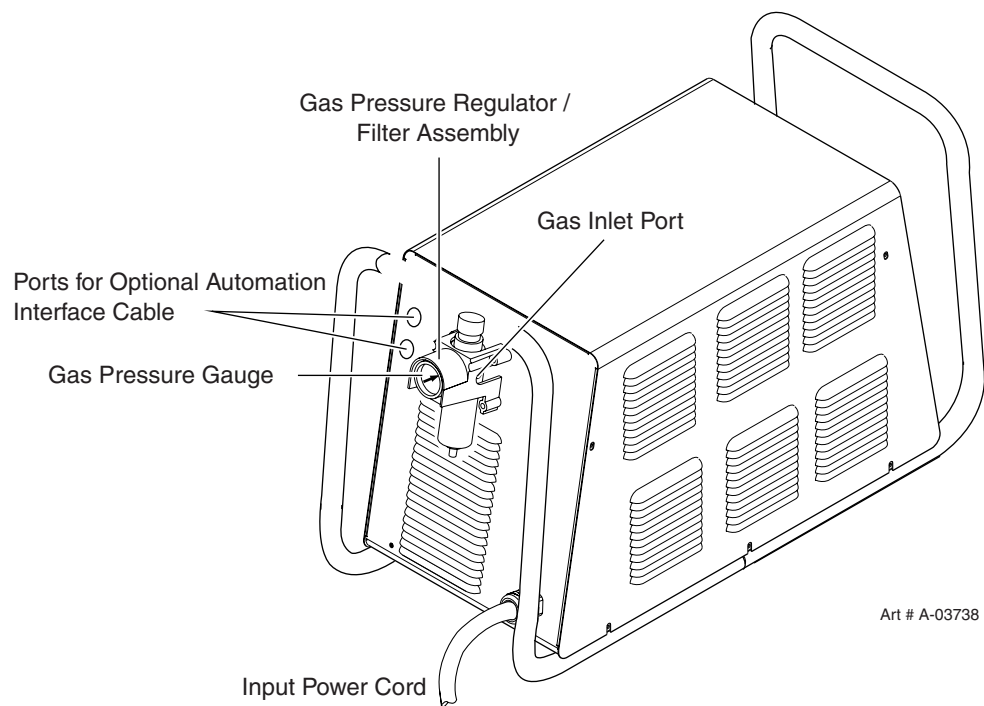
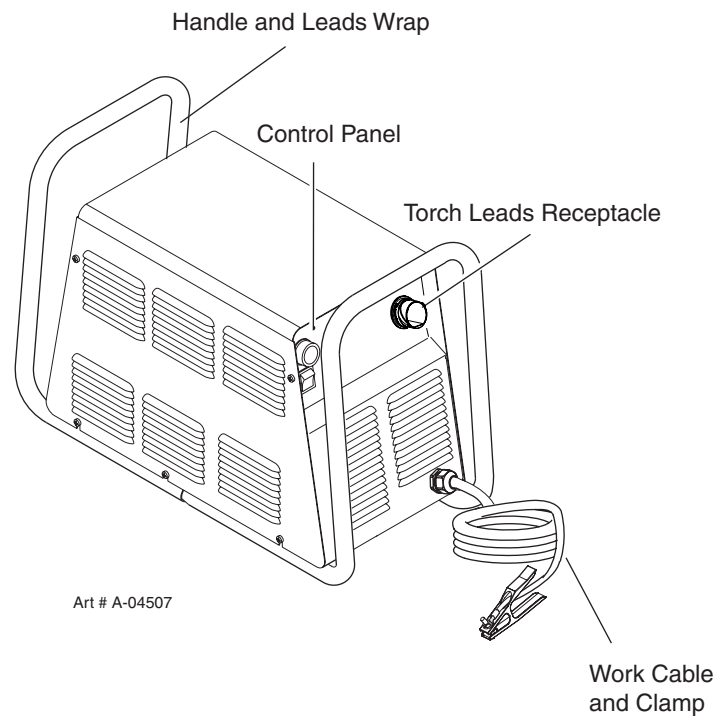

## 2.05 Power Supply Options and Accessories

Section 6, Parts Lists, provides catalog numbers and ordering information.

### A. Single-Stage Air Filter Kit

For use with compressed air shop systems. Filters moisture and particulate matter from the air stream to at least 0.85 microns. This filter increases performance and improves consumables parts life.

### B. Two Stage Air Filter Kit

For use on compressed air shop systems. Filters moisture and contaminants from the air stream to at least 5.0 microns. This filter is pre-assembled at the factory and needs only to be installed on the power supply.

### C. High Pressure Regulators

High pressure regulators are available. The regulators are used to set the proper compressed air pressure.

---

*NOTE*

---

*Regulators should not be installed with In-Line Air Filters.*

### D. Extended Work Cable with Clamp

As an alternative to the standard 20 ft / 6.1 m work cable & clamp on the power supply, a 50 ft / 15.2 m work cable with clamp is available.

### E. Multi-Purpose Cart

Rugged steel cart on easy-rolling rear wheels and front-mounted swivel casters. Provides maximum mobility for the power supply and can also serve as a display cart. Top shelf is 12" / 305 mm x 20" / 508 mm. Steel handle is 30" / 762 mm high.

### F. Automation Interface Kit

This kit allows the user to convert a non automated power supply for use as part of a fully automated system. The kit includes an automation interface board, wiring harness, mounting hardware and instructions. The automation interface provides the basic start / stop and OK to move functions, and a switch selectable voltage divider output. An external connector simplifies the connection to a CNC type cutting machine. CNC cables are available in 25' / 7.6 m and 50' / 15.m lengths for use with this kit.

### G. Vinyl Cover

Nylon canvas power supply dust cover with water resistant finish, large outer pocket for storing manuals or spare consumables, and adjustable draw cord for tight fit.



## SECTION 3: INSTALLATION

---

### 3.01 Unpacking

1. Use the packing lists to identify and account for each item.
2. Inspect each item for possible shipping damage. If damage is evident, contact your distributor and / or shipping company before proceeding with the installation.
3. Record Power Supply and Torch model and serial numbers, purchase date and vendor name, in the information block at the front of this manual.

### 3.02 Lifting Options

The Power Supply includes a handle for **hand lifting only**. Be sure unit is lifted and transported safely and securely.



#### WARNINGS

---

*Do not touch live electrical parts.*

*Disconnect input power cord before moving unit.*

***FALLING EQUIPMENT** can cause serious personal injury and can damage equipment.*

***HANDLE** is not for mechanical lifting.*

---

- Only persons of adequate physical strength should lift the unit.
- Lift unit by the handle, using two hands. Do not use straps for lifting.
- Use optional cart or similar device of adequate capacity to move unit.
- Place unit on a proper skid and secure in place before transporting with a fork lift or other vehicle.

### 3.03 Primary Input Power Connections

---

**CAUTION**

*Check your power source for correct voltage before plugging in or connecting the unit. The primary power source, fuse, and any extension cords used must conform to local electrical code and the recommended circuit protection and wiring requirements as specified in Section 2.03.*

#### **A. Connections to 208 / 230 - Volt Power**

The 208 / 230 - Volt power supply includes a factory - installed input power cable and plug.

1. Check your power source for correct voltage before plugging in the unit.
2. Connect the input power cable (or close the main disconnect switch) to supply power to the system.

---

**CAUTION**

*The primary power source and power cable must conform to local electrical code and the recommended circuit protection and wiring requirements (refer to table in Section 2.03).*

#### **B. Connections to 400 - Volt, 460 - Volt, or 600 - Volt Three - Phase Power**

These Power Supplies are equipped with a four - conductor input power cable for three - phase input power. The 460 - Volt Power Supply will accept 460 - VAC, Single - Phase input power with a change of input power cable.

1. The input cable's outer covering is stripped back at the factory to expose the individual wires at the free end of the cable.
2. Connect the ends of the individual wires to a customer supplied plug or main disconnect as follows:

---

**CAUTION**

*The primary power source and power cable must conform to local electrical code and the recommended circuit protection and wiring requirements (refer to table in Section 2 ). All the input cable wires must be connected for three - phase operation.*

- Green / Yellow wire to Ground.
  - Remaining wires to L1, L2, L3 input.
3. Connect the input power cable (or close the main disconnect switch) to supply power to the system.

### C. Connections to 460 - Volt Single- Phase Power

The 460 - Volt Power Supply will accept 460 - VAC, Single - Phase input power with a change of input power cable.

1. Remove the Power Supply cover per section 5.04.
2. Disconnect the original input power cable from the main input contactor and the chassis ground connection.
3. Loosen the through - hole protector on the back panel of the power supply. Pull the original power cable out of the power supply.
4. Pass a customer - supplied, three - conductor input power cable through the access opening in the back panel of the power supply. Refer to Section 2 for power cable specifications. Tighten the through - hole protector to secure the power cable.

#### ■ CAUTION

*The primary power source and power cable must conform to local electrical code and the recommended circuit protection and wiring requirements (refer to table in Section 2.03).*

5. Strip back the insulation on the individual wires.
6. Connect to main input contactor as follows:
  - Line 1 wire to terminal L1.
  - Line 3 wire to terminal L3.
7. Connect the ground wire to Ground (Earth). The Ground wire connection requires a ring terminal.

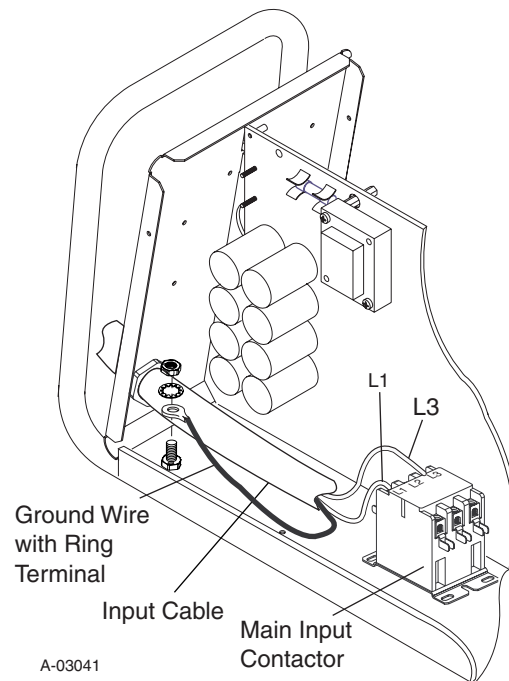

Input Power Connections, 460 VAC, Single - Phase

8. Replace the Power Supply cover.
9. Connect the input power cable (or close the main disconnect switch) to supply power to the system.

## 3.04 Gas Connections

### A. Connecting Gas Supply to Unit

Use only compressed air with this power supply.

The connection is the same for compressed air from a compressor from high pressure cylinders. Refer to subsection 3.4-B or 3.4-C if an optional air line filter is to be installed.

1. Connect the air line to the inlet port. The illustration shows typical fittings as an example. Other fittings can be used.

#### NOTE

*For a secure seal, apply thread sealant to the fitting threads, according to manufacturer's instructions. Do not use Teflon tape as a thread sealer, as small particles of the tape may break off and block the small air passages in the torch.*

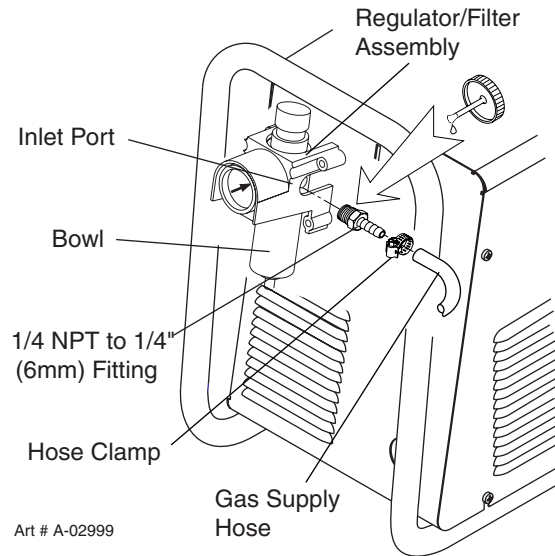

Air Connection to Inlet Port

## B. Installing Optional Single - Stage Air Filter

An optional filter kit is recommended for improved filtering with compressed air, to keep moisture and debris out of the torch.

1. Attach the Single - Stage Filter Hose to the Inlet Port.
2. Attach the Filter Assembly to the filter hose.
3. Connect the air line to the Filter. The illustration shows typical fittings as an example.

### NOTE

*For a secure seal, apply thread sealant to the fitting threads, according to the maker's instructions. Do Not use Teflon tape as a thread sealer, as small particles of the tape may break off and block the small air passages in the torch. Connect as follows:*

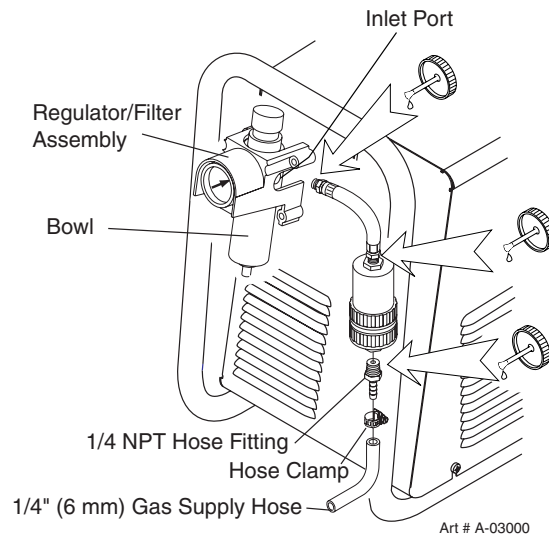

Optional Single - Stage Filter Installation

### C. Installing Optional Two - Stage Air Filter Kit

This optional two - stage air line filter is also for use on compressed air shop systems. Filter removes moisture and contaminants to at least 5 microns.

Connect the air supply as follows:

- a. Attach the Two Stage Filter bracket to the back of the power supply per instructions supplied with the filter assembly.

---

**NOTE**

---

*For a secure seal, apply thread sealant to the fitting threads according to manufacturer's instructions. Do Not use Teflon tape as a thread sealer as small particles of the tape may break off and block the small air passages in the torch.*

- b. Connect the two stage filter outlet hose to the inlet port of the Regulator / Filter Assembly.
- c. Use customer - supplied fittings to connect the air line to the Filter. A 1/4 NPT to 1/4" hose barbed fitting is shown as an example.

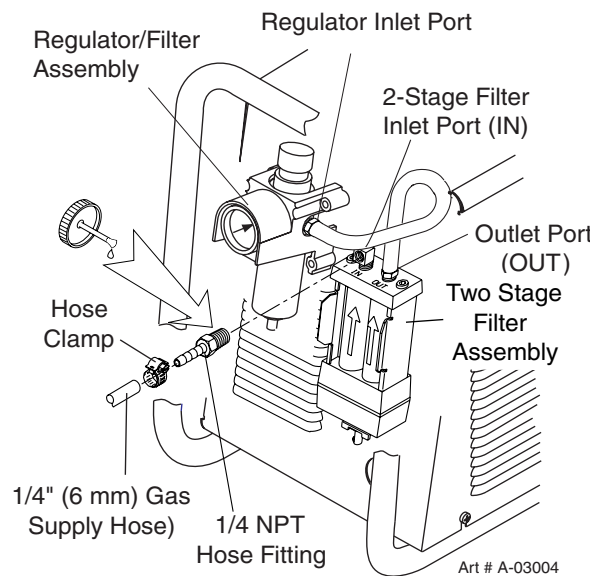

Optional Two - Stage Filter Installation

## D. Using High Pressure Air Cylinders

When using high pressure air cylinders as the air supply:

1. Refer to the manufacturer's specifications for installation and maintenance procedures for high pressure regulators.
2. Examine the cylinder valves to be sure they are clean and free of oil, grease or any foreign material. Briefly open each cylinder valve to blow out any dust which may be present.
3. The cylinder must be equipped with an adjustable high - pressure regulator capable of outlet pressures up to 100 psi (6.9 bar) maximum and flows of at least 500 scfh (236 lpm).
4. Connect supply hose to the cylinder.

---

### NOTE

*Pressure should be set at 100 psi (6.9 bar) at the high pressure cylinder regulator.*

*Supply hose must be at least 1/4 inch (6 mm) I.D.*

*For a secure seal, apply thread sealant to the fitting threads, according to manufacturer's instructions. Do Not use Teflon tape as a thread sealer, as small particles of the tape may break off and block the small air passages in the torch.*

### 3.05 Torch Connections

If necessary, connect the torch to the Power Supply. Connect only the Thermal Dynamics model SL60 or SL100 Torch (with ATC connector) to this power supply. Maximum torch leads length is 100 feet / 30.5 m, including extensions.



**WARNING**

---

*Disconnect primary power at the source before connecting the torch.*

---

1. Align the ATC male connector (on the torch lead) with the female receptacle. Push the male connector into the female receptacle. The connectors should push together with a small amount of pressure.
2. Secure the connection by turning the locking nut clockwise until it clicks. **DO NOT** use the locking nut to pull the connection together. Do not use tools to secure the connection.
3. The system is ready for operation.

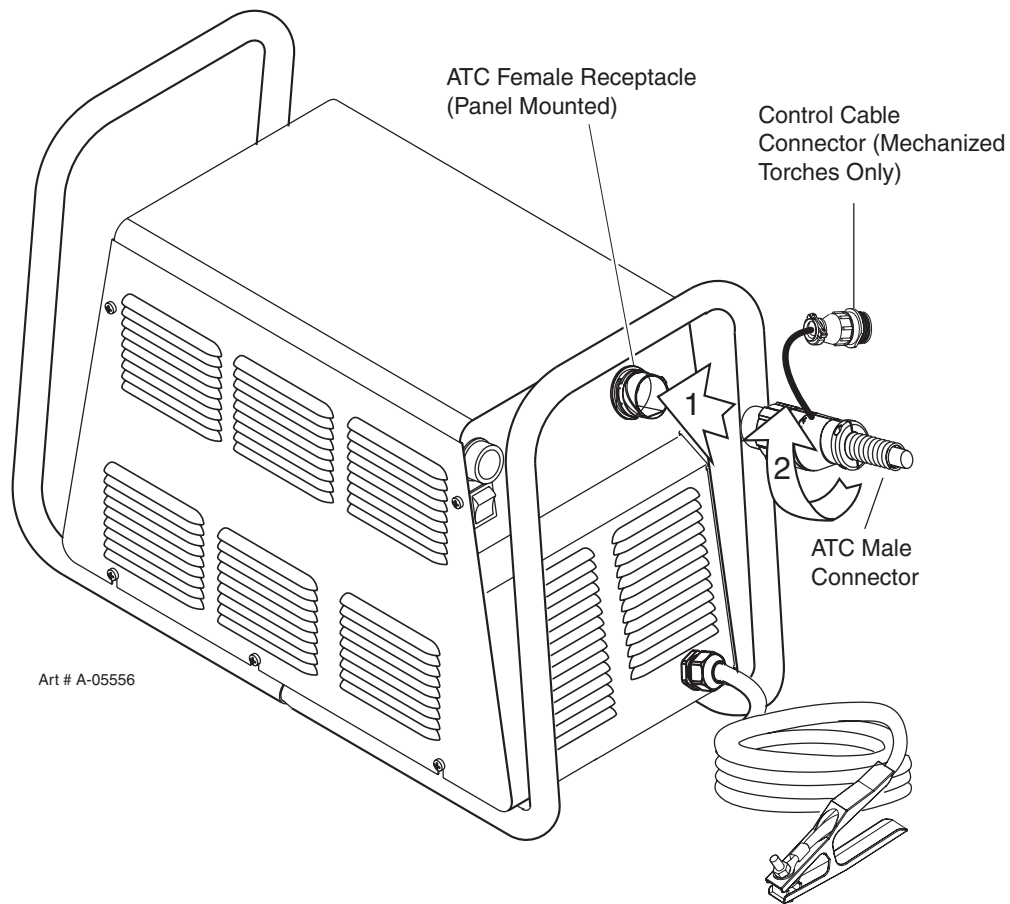

Connecting the Torch to the Power Supply



## B. Check Air Quality

To test the quality of air:

1. Put the ON / OFF switch in the ON (up) position.
2. Put the RUN / RAPID AUTO RESTART / SET switch in the SET (down) position.
3. Place a welding filter lens in front of the torch and turn on the air. Any oil or moisture in the air will be visible on the lens. **Do not start an arc!**

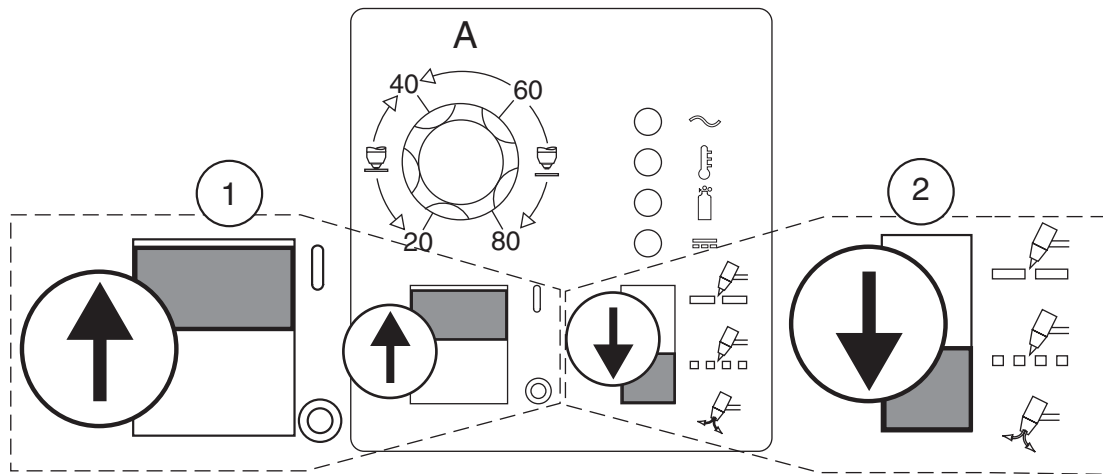

Art # A-03577

This Page Intentionally Blank

# SECTION 4: OPERATION

## 4.01 Product Features

### A. Front Panel Controls and Indicators

#### (A) Output Current Control

Sets the desired output current. Output settings up to 40 Amps may be used for drag cutting (with the torch tip contacting the workpiece). At output settings over 40 Amps, the power supply automatically reduces output current to 40 Amps if the tip touches the workpiece.

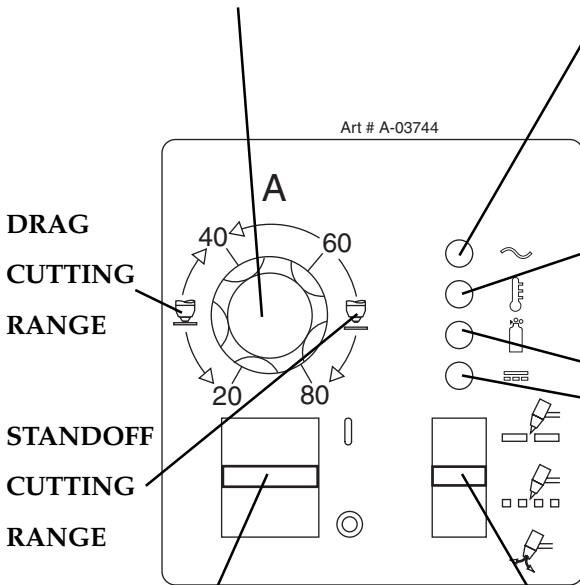

#### AC Indicator

Steady light indicates power supply is ready for operation. Blinking light indicates unit is in protective interlock mode. Shut unit off, shut off or disconnect input power, correct the fault, and restart the unit. Refer to Section 5 for details.

#### TEMP Indicator

Indicator is normally OFF. Indicator is ON when internal temperature exceeds normal limits. Shut unit OFF; let the unit cool before continuing operation.

#### GAS Indicator

Indicator is ON when minimum input gas pressure for power supply operation is present. Minimum pressure for power supply operation is not sufficient for torch operation.

#### DC Indicator

Indicator is ON when DC output circuit is active.

#### ON / OFF Switch

Controls input power to the power supply. Up is ON, down is OFF.

#### RUN / RAPID AUTO RESTART / SET Switch

RUN (up) position is for general torch operation.

RAPID AUTO RESTART (middle) position is for an uninterrupted restart, when cutting expanded metal or in gouging or trimming operations.

SET (down) position is for setting gas pressure and purging lines.

## 4.02 Preparations For Operating

Perform the following steps at the start of each operating session:



---

*Disconnect primary power at the source before assembling or disassembling power supply, torch parts, or torch and leads assemblies.*

---

### A. Torch Parts Selection

Check the torch for proper assembly and appropriate torch parts. The torch parts must correspond with the type of operation, and with the amperage output of this Power Supply (80 amps maximum). Refer to the Torch Manual.

### B. Torch Connection

Check that the torch is properly connected. Only Thermal Dynamics model SL60 or SL100 Torches may be connected to this Power Supply.

### C. Check Primary Input Power Source

1. Check the power source for proper input voltage. Make sure the input power source meets the power requirements for the unit per Section 2, Specifications.
2. Connect the input power cable (or close the main disconnect switch) to supply power to the system.

### D. Gas Selection

Ensure compressed air source meets requirements (refer to Section 3.4). Check connections and turn gas supply on.

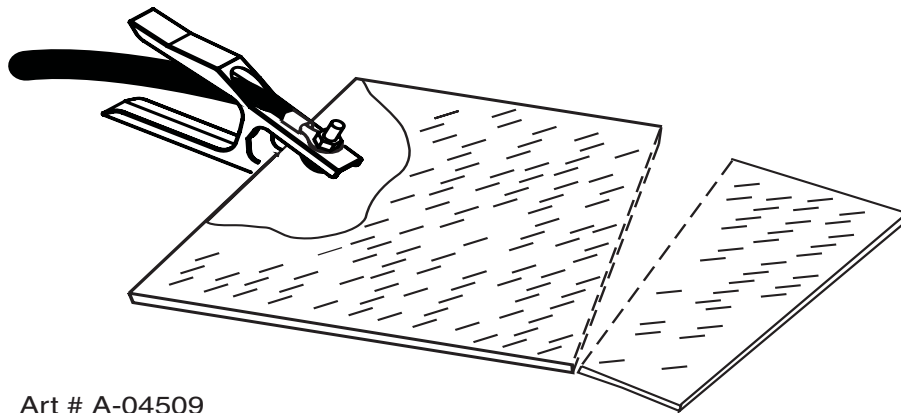

### E. Connect Work Cable

Clamp the work cable to the workpiece or cutting table. The area must be free from oil, paint and rust. Connect only to the main part of the workpiece; do not connect to the part to be cut off.



Art # A-04509

## F. Power On

Place the Power Supply ON / OFF switch to the ON (up) position. AC indicator  turns on. Gas indicator  turns on if there is sufficient gas pressure for power supply operation.

---

### NOTE

*Minimum pressure for power supply operation is lower than minimum for torch operation.*

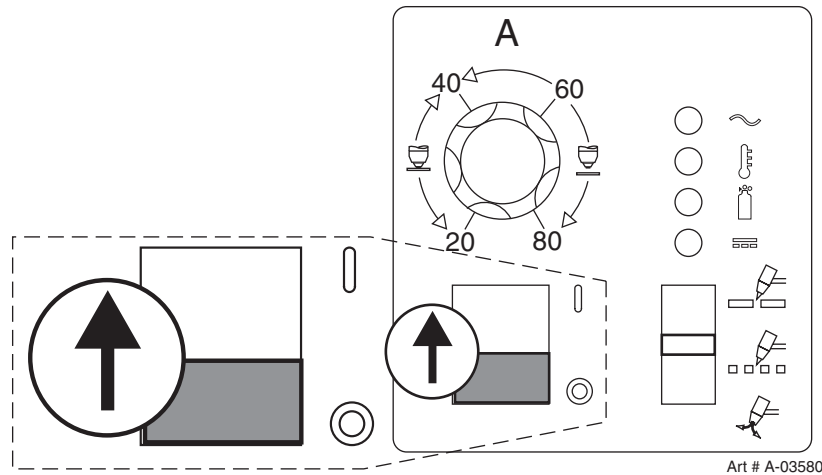

## G. Set Operating Pressure

1. Place the Power Supply RUN / Rapid Auto Restart / SET switch to the SET (down) position. Gas will flow.

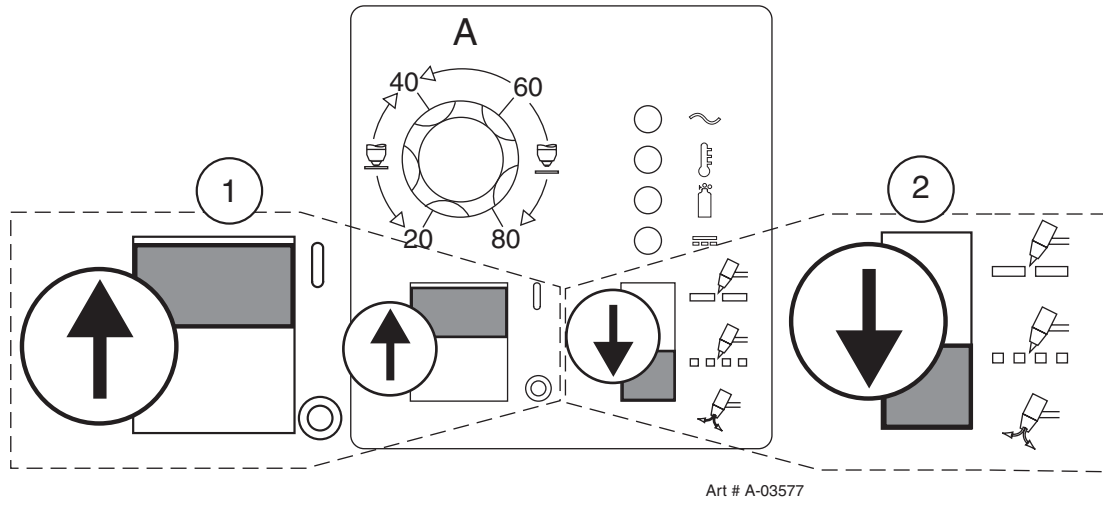

2. Adjust gas pressure per the settings chart.

<b>CutMaster 101 Gas Pressure Settings</b>	
<b>Leads Length</b>	SL100 (Hand Torch or Machine Torch)
Up to 25' (7.6 m)	70 psi 4.8 bar
Over 25' (7.6 m)	75 psi 5.2 bar

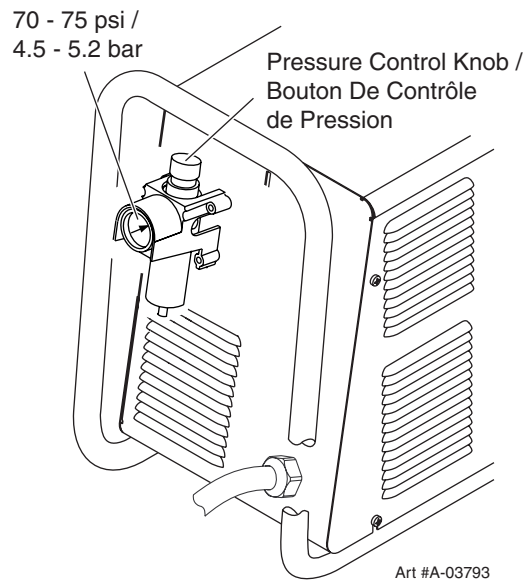

## H. Select Current Output Level

1. Place RUN / Rapid Auto Restart / SET to RUN (up) or Rapid Auto Restart (center) position. Gas flow stops.
2. Set the current output level, up to 40 amps for drag cutting (with the torch tip in contact with the workpiece), or up to 80 amps for standoff cutting. At output settings higher than 40 amps, the power supply automatically reduces output current to 40 amps if the torch tip contacts the workpiece.

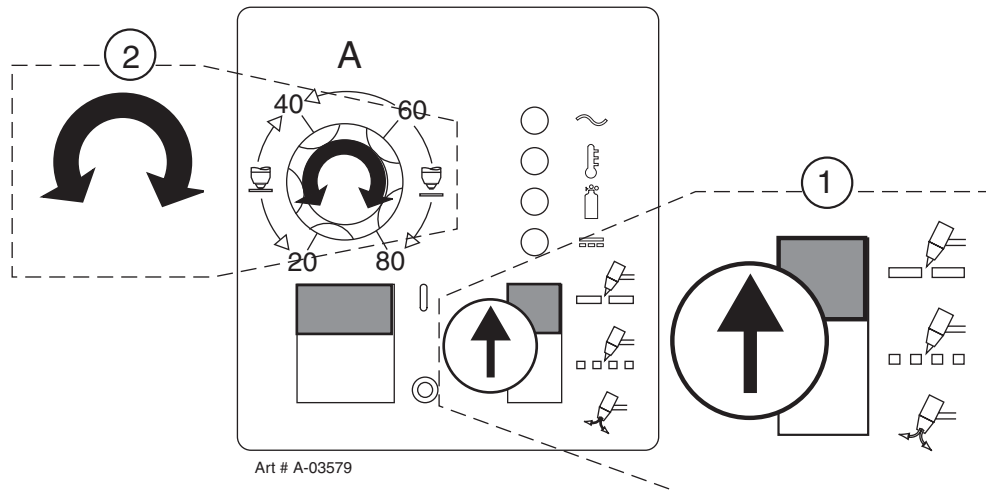

## I. Cutting Operation

Refer to the manual supplied with the torch for details on cutting operation, cutting speeds, parts selection and replacement, etc.

When the torch leaves the workpiece during cutting operations with the RUN / Rapid Auto Restart / SET switch in the RUN (up) position, there is a brief delay in restarting the pilot arc. With the switch in the 'Rapid Auto Restart' (middle) position, when the torch leaves the workpiece the pilot arc restarts instantly, and the cutting arc restarts instantly when the pilot arc contacts the workpiece. Use the 'Rapid Auto Restart' position when cutting expanded metal or gratings, or in gouging or trimming operations when an uninterrupted restart is desired.

### NOTE

*When the shield cup is properly installed, there is a slight gap between the shield cup and the torch handle. Gas vents through this gap as part of normal operation. Do not attempt to force the shield cup to close this gap. Forcing the shield cup against the torch head or torch handle can damage components.*

## J. Typical Cutting Speeds

Cutting speeds vary according to torch output amperage, the type of material being cut, and operator skill. Refer to the Torch Manual for details.

Output current setting or cutting speeds may be reduced to allow slower cutting when following a line, or using a template or cutting guide while still producing cuts of excellent quality.

## K. Postflow

Release the trigger to stop the cutting arc. Gas continues to flow for approximately 6 seconds. During post - flow, if the user moves the trigger release to the rear and presses the trigger, the pilot arc starts. The main arc transfers to the workpiece if the torch tip is within transfer distance to the workpiece.

## L. Shutdown

Turn the ON / OFF switch to OFF (down). All Power Supply indicators shut off. Unplug the input power cord or disconnect input power. Power is removed from the system.

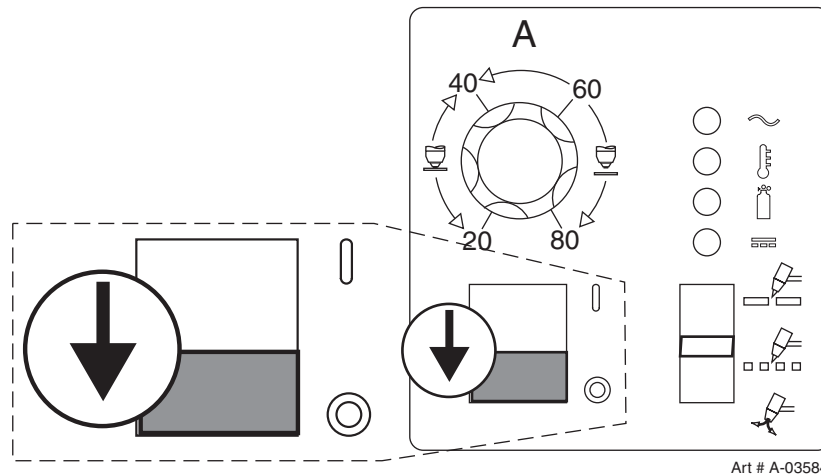



# SECTION 5: SERVICE

---

## 5.01 General Maintenance

### A. O-Ring Lubrication

An o-ring on the Torch ATC Male Connector requires lubrication on a regular basis, depending on how frequently the torch is disconnected and re-connected. This will allow the o-ring to remain pliable and provide a proper seal. The o-ring will dry out, becoming hard and cracked, if the o-ring lubricant is not used on a regular basis. This can lead to potential performance problems.

It is recommended to apply a very light film of o-ring lubricant (Catalog #8-4025) to the o-ring on a weekly basis.

#### NOTE

*DO NOT use other lubricants or grease, they may not be designed to operate within high temperatures or may contain "unknown elements" that may react with the atmosphere. This reaction can leave contaminants inside the torch. Either of these conditions can lead to inconsistent performance or poor parts life.*

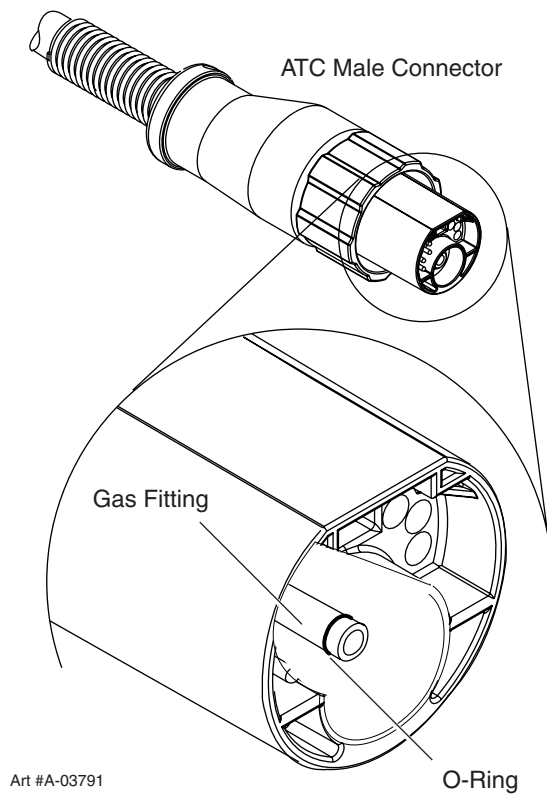

## B. Filter Element Replacement

The Regulator/Filter Assembly is on the rear panel. For better system performance, the Regulator/Filter Assembly filter element should be checked per the Maintenance Schedule (Appendix 3), and either cleaned or replaced.

1. Remove power from the power supply; turn off the gas supply and bleed down the system.
2. Unscrew the bowl on the bottom of the Regulator/Filter Assembly. The filter element will be visible and still attached to the main body of the Regulator/Filter.
3. Grasp the filter element and unscrew it from the Regulator/Filter body. The filter element will come off with a spool and some additional pieces.
4. Note the correct assembly of the filter/spool then remove the filter from the spool and either clean it or replace it.
5. The filter element and spool, with the baffle ring in place (teeth facing downward) can be screwed back into the Regulator body by compressing the spring on the spool. Tighten firmly by hand.

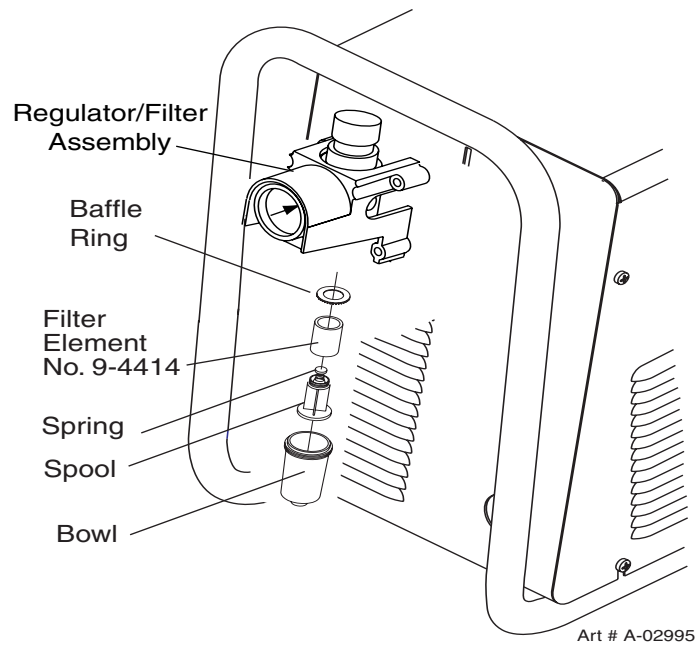

### Regulator/Filter Element Replacement

6. Reinstall the bowl.
7. Turn on the air supply.

### C. Optional Single-Stage Filter Element Replacement

These instructions apply to power supplies where the optional Single-Stage Filter has been installed.

The Power Supply shuts down automatically when the Filter Element becomes completely saturated. The Filter Element can be removed from its housing, dried, and reused. Allow 24 hours for Element to dry. Refer to Section 6, Parts List, for replacement filter element catalog number.

1. Remove power from power supply.
2. Shut off air supply and bleed down system before disassembling Filter to change Filter Element.
3. Disconnect gas supply hose.
4. Turn the Cover counter-clockwise and remove it from the Filter Housing. The Filter Element is located inside the Housing.

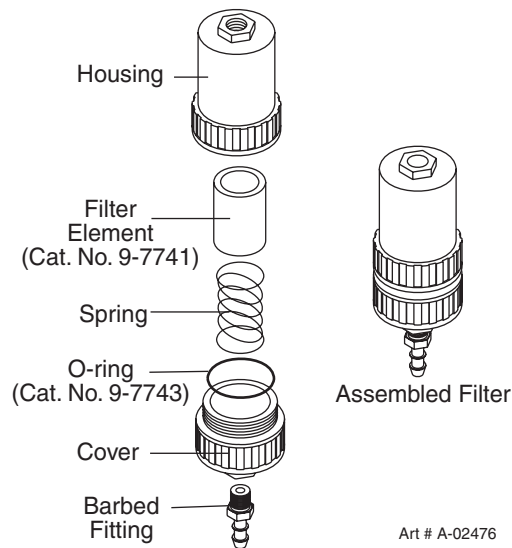

#### Optional Single-Stage Filter Element Replacement

5. Remove the Filter Element from the Housing and set Element aside to dry.
6. Wipe inside of housing clean, then insert the replacement Filter Element open side first.
7. Replace Housing on Cover.
8. Reattach gas supply.

#### **NOTE**

---

*If unit leaks between housing and cover, inspect the "O" Ring for cuts or other damage.*

## D. Optional Two-Stage Filter Element Replacement

The Two-Stage Air Filter has two Filter Elements. When the Filter Elements become dirty the Power Supply will continue to operate but cut quality may become unacceptable. Refer to Section 6, Parts List, for replacement filter element catalog number.

1. Shut off primary input power.
2. Shut off air supply and bleed down system.



---

*Always turn off the air supply and bleed the system before disassembling the Filter Assembly as injury could result.*

---

3. Loosen the two bolts on the top of the Filter Assembly enough to allow the Filter Elements to move freely.
4. Note the location and orientation of the old Filter Elements.
5. Slide out the old Filter Elements.

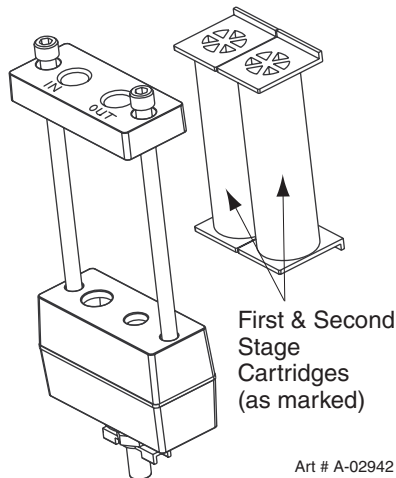

### Optional Two-Stage Filter Replacement

6. Slide the replacement Filter Elements into the Filter Assembly, with the same orientation as noted in Step 4 above.
7. Hand tighten the two bolts evenly, then torque each bolt to 20 - 30 in-lbs (2.3 - 3.4 Nm). Improper torque may damage the gasket.
8. Slowly apply air pressure to the assembly, checking for leaks.

---

#### **NOTE**

*A small amount of air leakage from the bottom fitting is normal.*

## 5.02 Common Faults

### 1. Insufficient Penetration

- a. *Cutting speed too fast*
- b. *Torch tilted too much*
- c. *Metal too thick*
- d. *Worn torch parts*
- e. *Cutting current too low*
- f. *Non - Genuine Thermal Dynamics parts used*
- g. *Incorrect gas pressure*

### 2. Main Arc Extinguishes

- a. *Cutting speed too slow*
- b. *Torch standoff too high from workpiece*
- c. *Cutting current too high*
- d. *Work cable disconnected*
- e. *Worn torch parts*
- f. *Non - Genuine Thermal Dynamics parts used*

### 3. Excessive Dross Formation

- a. *Cutting speed too slow*
- b. *Torch standoff too high from workpiece*
- c. *Worn torch parts*
- d. *Improper cutting current*
- e. *Non - Genuine Thermal Dynamics parts used*
- f. *Incorrect gas pressure*

### 4. Short Torch Parts Life

- a. *Oil or moisture in air source*
- b. *Exceeding system capability (material too thick)*
- c. *Excessive pilot arc time*
- d. *Gas pressure too low*
- e. *Improperly assembled torch*
- f. *Non - Genuine Thermal Dynamics parts used*

### 5. Difficult Piloting

- a. *Worn torch parts*
- b. *Non - Genuine Thermal Dynamics parts used*
- c. *Incorrect gas pressure*

## 5.03 Basic Troubleshooting Guide



---

*There are extremely dangerous voltage and power levels present inside this unit. Do not attempt to diagnose or repair unless you have had training in power electronics measurement and troubleshooting techniques.*

---

### A. Basic Troubleshooting: Overview

This guide covers basic troubleshooting. It is helpful for solving many of the common problems that can arise with this system. If major complex subassemblies are faulty, the unit must be returned to an authorized service center for repair.

Follow all instructions as listed and complete each section in the order presented.

For major troubleshooting and parts replacement procedures refer to the Power Supply Service Manual for this product.

### B. How to Use This Guide

The following information will help the Customer / Operator determine the most likely causes for various symptoms. Follow all instructions as listed and complete each section in the order presented.

This guide is set up in the following manner:

#### X. Symptom (Bold Type)

Any Special Instructions

1. *Cause*
  - a. Check / Remedy

Locate your **symptom**, check the *causes* (easiest listed first), then remedies. Repair as needed being sure to verify that unit operates properly after any repairs.

### C. Common Symptoms

#### A. AC indicator $\sim$ OFF

1. *Switch at main power panel in OFF (open) position.*
  - a. Close main power switch.
2. *Power Supply ON / OFF switch in OFF (down) position.*
  - a. Turn switch to ON (up).
3. *Torch is not connected properly to Power Supply*
  - a. Turn power supply ON / OFF switch to OFF (down). Check torch connection to Power Supply. Tighten or adjust as required. Do not use tools. Turn power supply ON / OFF switch to ON (up).
4. *Shield cup not fully tightened on torch head*
  - a. Check shield cup for proper installation. Do not overtighten. Do not use tools to tighten.
5. *Main power line fuse(s) or circuit breaker(s) blown*
  - a. Check main power panel fuse(s). Replace as required.

6. *Unit internal fuse blown or loose*

- a. If blown, double-check input voltage and replace fuse per Section 5.04-C. If fuse blows again, return unit to an authorized service center.

7. *Actual input voltage does not correspond to voltage of unit*

- a. Verify that the input line voltage is correct. Refer to Section 2, Input Wiring Requirements.

8. *Faulty components in unit*

- a. Return for repair or have qualified technician repair per Service Manual.

**B. Gas flows continuously when power is turned on, AC indicator  flashes**

1. *Torch switch is activated (closed) before user turns power on.*

- a. Release torch switch.

2. *Faulty torch switch*

- a. Check torch switch for continuity. Replace if necessary.

**C. Gas flows continuously; Torch will not pilot when torch switch is activated; AC indicator  ON**

1. *System is in SET mode*

- a. Change RUN / Rapid Auto Restart / SET switch to RUN (up).

**D. No gas flow; RUN / Rapid Auto Restart / SET switch in SET position; Fans operate; AC indicator  ON;**

**GAS indicator  OFF**

1. *Gas not connected*





- a. Check gas connections.

2. *Gas pressure too low for power supply operation*

- a. Adjust gas pressure per torch manual.

3. *Faulty components in unit*

- a. Return for repair or have qualified technician repair.

**E. Torch will not pilot; gas flows; AC indicator  ON, GAS , TEMP , and DC  indicators OFF**

1. *Gas pressure is below power supply minimum requirement.*

- a. Adjust pressure to 60 - 75 psi / 4.1 - 5.2 bar.

**F. Torch will not pilot; gas flows; AC  and Gas indicators  ON; DC  and TEMP  indicators OFF**

1. *Gas pressure is below torch minimum requirement (Minimum pressure for power supply operation is lower than minimum required for torch operation.)*

- a. Adjust gas pressure per torch manual.

G. Torch will not pilot; no gas flow; AC indicator  ON, GAS indicator  ON, DC indicator  ON

1. *Starter cartridge missing from torch*
  - a. Shut off power supply. Remove shield cup, install starter cartridge. Reinstall torch tip and shield cup. Turn power supply ON / OFF switch to ON (up).
2. *Shield cup is loose on torch*
  - a. Check shield cup; tighten if necessary.

**NOTE**

*When operating the torch in a normal condition, a small amount of gas vents through the gap between the shield cup and torch handle. Do not attempt to over tighten the shield cup as irreparable damage to internal components may result.*

3. *Upper O-ring on torch head is in wrong position.*
  - a. Remove shield cup from torch; check position of upper O-ring. Correct if necessary.

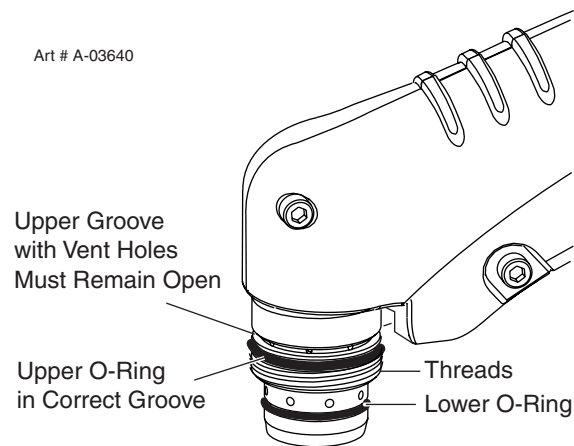

H. Torch will not pilot; AC , GAS , and TEMP  indicators ON, DC  indicator OFF

1. *Air flow blocked*
  - a. Check for blocked air flow around the unit and correct condition.
2. *Unit is overheated*
  - a. Let unit cool down for at least 5 minutes. Make sure the unit has not been operated beyond Duty Cycle limit. Refer to duty cycle data in Section 2.
3. *Input line voltage is low*
  - a. Check and connect to proper input power line.
4. *Faulty components in unit*
  - a. Return for repair or have qualified technician repair per Service Manual.







**I. Torch cannot be activated; AC indicator  flashing; Gas indicator  ON; Temp indicator  OFF; DC indicator  OFF**

1. *System is in protective interlock mode. (User held torch trigger while turning on ON / OFF switch.)*
  - a. Release torch trigger.
2. *System is in protective interlock mode. (Torch parts are missing or loose.)*
  - a. Release torch trigger, and set power supply ON / OFF switch to OFF (down). Open main disconnect switch. Check torch parts. Replace parts as needed. Reinstall shield cup; hand - tighten it securely against the torch head. Do not overtighten. Do not use tools. Close main disconnect switch. Set ON / OFF switch to ON (up) position.

**J. Gas cycles on and off without torch switch being activated; AC indicator  Flashing; Gas indicator  ON; DC indicator  OFF**

1. *Torch tip or electrode missing*
  - a. Shut off power supply. Remove shield cup, install missing part(s). Turn power supply ON / OFF switch to ON (up).

**K. No cutting output; Torch pilots; Gas flows; Fans operate; AC  , Gas  , and DC  indicator ON; TEMP  indicator OFF**





1. *Work cable not connected to work piece, or connection is poor*
  - a. Make sure that work cable has a proper connection to a clean, dry area of the workpiece.
2. *Faulty Torch*
  - a. Return for repair or have qualified technician repair.
3. *Faulty components in unit*
  - a. Return for repair or have qualified technician repair per Service Manual.

**L. Torch cuts but not adequately**

1. *Incorrect setting of output current (A) control*
  - a. Check and adjust to proper setting.
2. *Torch consumables worn*
  - a. Check torch consumables per Torch manual; replace as needed.
3. *Work cable connection to work piece is poor*
  - a. Make sure that work cable has a proper connection to a clean, dry area of the workpiece.
4. *Torch is being moved too fast across workpiece*
  - a. Reduce cutting speed.
5. *Torch being dragged on work. ('Tip saver' circuit active) At output current settings greater than 40 amps, the power supply automatically reduces current to 40 amps if the torch tip contacts the workpiece.*
  - a. Lift torch off work.

6. *Excessive oil or moisture in torch*
  - a. Put RUN / RAPID AUTO RESTART / SET switch in SET (down) position. Hold torch 1/8 inch (3 mm) from clean surface while purging and observe oil or moisture buildup (do not activate torch). If there are contaminants in the gas, additional filtering may be needed.
7. *Fluctuations in input power*
  - a. Have electrician check input line voltage.
8. *Faulty components in unit*
  - a. Return for repair or have qualified technician repair per Service Manual.

**M. Arc shuts off during operation; arc will not restart when torch switch is activated.**

1. *Power Supply is overheated (TEMP  indicator ON)*
  - a. Let unit cool down for at least 5 minutes. Make sure the unit has not been operated beyond Duty Cycle limit. Refer to Section 2 for duty cycle specifications.
2. *Fan blades blocked (TEMP  indicator ON)*
  - a. Check and clear blades.
3. *Air flow obstructed (TEMP  indicator ON)*
  - a. Check for obstructed air flow around the unit and correct condition.
4. *Gas pressure too low (GAS indicator  OFF when torch switch is activated)*
  - a. Check source for at least 60 psi / 4.1 bar; adjust as needed. (Minimum pressure for power supply operation is lower than minimum required for torch operation.)
5. *Torch consumables worn*
  - a. Check torch consumables per Torch manual; replace as needed.
6. *Faulty components in unit*
  - a. Return for repair or have qualified technician repair per Service Manual.

**N. AC indicator  remains ON when shield cup is removed**

1. *Faulty PIP switch in torch*
  - a. Check PIP switch for continuity; replace if necessary

## 5.04 Power Supply Basic Parts Replacement



**WARNING**

---

*Disconnect primary power to the system before disassembling the torch, leads, or power supply.*

---

This section describes procedures for basic parts replacement. For more detailed parts replacement procedures, refer to the Power Supply Service Manual.

### A. Cover Removal

1. Remove the upper screws which secure the cover to the main assembly.

---

#### **NOTE**

---

*There is a ground wire connection to the inside of the unit. There is no need to disconnect the ground wire, unless there is a need for more room to work.*

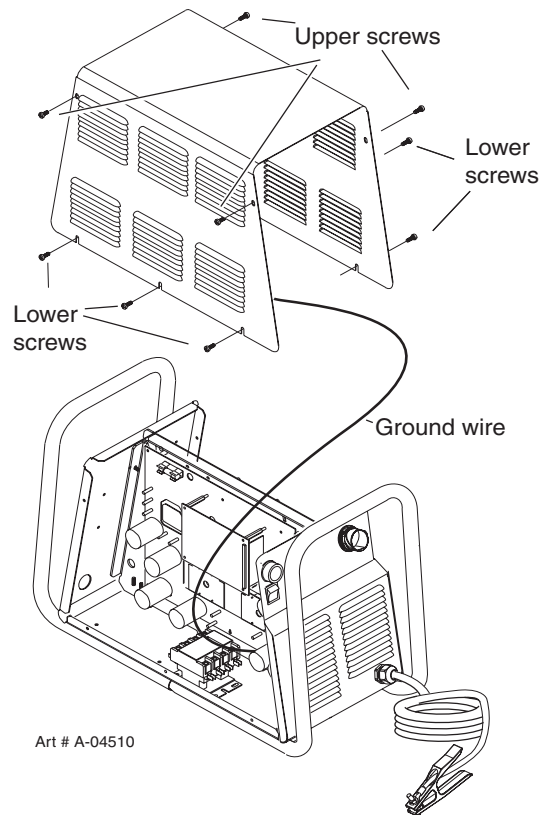

2. Loosen, but do not remove, the lower screws, then carefully pull the Cover up and away from the unit.

## B. Cover Installation

1. Reconnect the ground wire, if necessary.
2. Place the cover onto the power supply so that slots in the bottom edges of the cover engage the lower screws.
3. Tighten lower screws.
4. Reinstall and tighten the upper screws.

## C. Fuse Replacement

1. Remove the unit cover per paragraph "A" above.
2. Locate the internal fuse on the left side of the center chassis.
3. Replace the fuse. A replacement fuse is located inside the power supply. Refer to Section 6, Parts Lists, for replacement fuse catalog number.
4. Reinstall the cover by reversing the steps in paragraph "B" above.

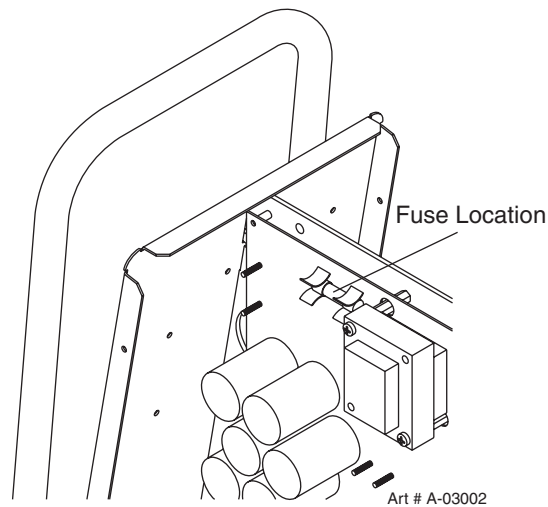

Internal Fuse Location

This completes the parts replacement procedures.

# SECTION 6: PARTS LISTS

---

## 6.01 Introduction

### A. Parts List Breakdown

The parts list provide a breakdown of all replaceable components. The parts lists are arranged as follows:

Section 6.03 Complete Power Supply Replacement

Section 6.04 Replacement Parts

Section 6.05 Options and Accessories

---

#### NOTE

---

*Parts listed without item numbers are not shown, but may be ordered by the catalog number shown.*

### B. Returns

If a product must be returned for service, contact your distributor. Materials returned without proper authorization will not be accepted.

## 6.02 Ordering Information

Order replacement parts by catalog number and complete description of the part or assembly, as listed in the parts list for each type item. Also include the model and serial number of the power supply. Address all inquiries to your authorized distributor.

## 6.03 Power Supply Replacement

The following items are included with the replacement power supply: work cable & clamp, input power cable, gas pressure regulator / filter, and operating manual.

Qty	Description	Catalog #
1	CutMaster 101 Power Supply 208 / 230VAC, Single - Phase, 50/60 Hz, with input power cable and plug	3-1320-1
1	400VAC, Three - Phase, 50/60 Hz, with input power cable	3-1320-3
1	460VAC, Three - Phase, 60 Hz, with input power cable	3-1320-2
1	600VAC, Three - Phase, 60 Hz, with input power cable	3-1320-5

## 6.04 Replacement Parts

Qty	Description	Catalog #
	Fuse	
1	for 208 / 230VAC Power Supply	9-8588
1	for 400VAC Power Supply	9-8602
1	for 460 Power Supply	9-8583
1	for 600VAC Power Supply	9-8638
1	Regulator / Filter Assembly Replacement Element	9-4414
	Input Power Cord	
	for 208 / 230VAC Power Supply	9-8596
1	for 400VAC Power Supply	9-8562
1	for 460 Power Supply	9-8593
1	for 600VAC Power Supply	9-8593

## 6.05 Options and Accessories

Qty	Description	Catalog #
1	Single-Stage Filter Kit (includes Filter & Hose)	7-7507
1	Replacement Filter Body	9-7740
1	Replacement Filter Hose (not shown)	9-7742
2	Replacement Filter Element	9-7741
1	Two-Stage Filter Kit (includes Hose & Mounting Screws)	7-7500
1	Bracket, Filter Mounting (not shown)	9-7535
1	Two-Stage Air Filter Assembly	9-7527
1	First Stage Cartridge	9-1021
1	Second Stage Cartridge	9-1022
1	Extended Work Cable ( 50 ft / 15.2 m ) with Clamp	9-8529
1	Multi-Purpose Cart	7-8888
1	Automation Interface Kit	9-8310
1	25' / 7.6 m CNC Cable for Automation Interface Kit	9-8312
1	50' / 15.2 m CNC Cable for Automation Interface Kit	9-8313
1	Nylon Dust Cover	9-7072

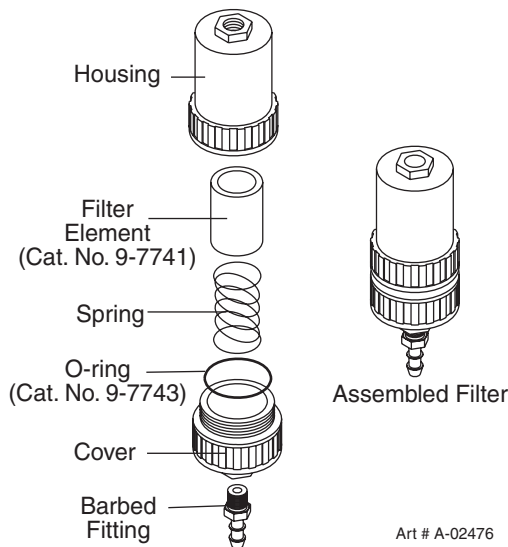

Optional Single-Stage Filter Kit

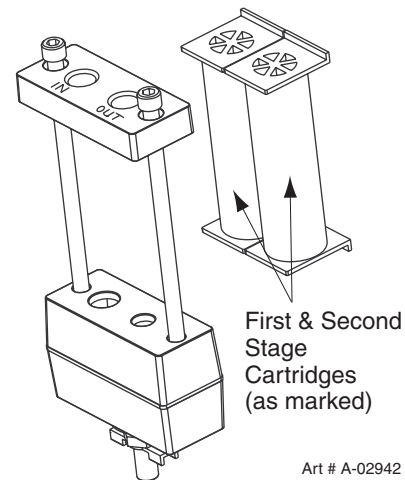

Optional Two-Stage Filter Kit

# 6.06 Torch Parts

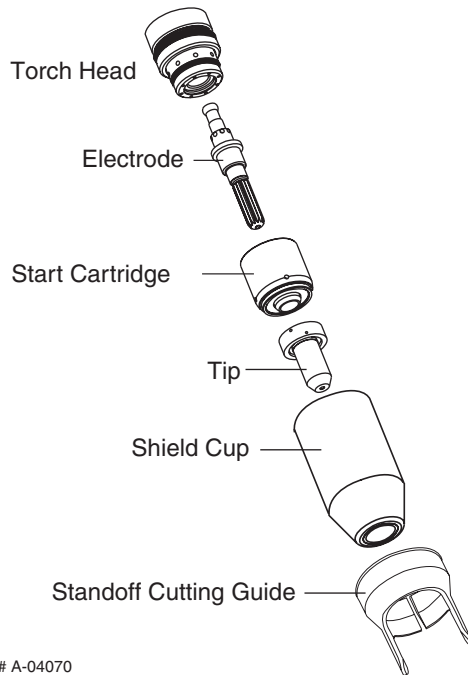
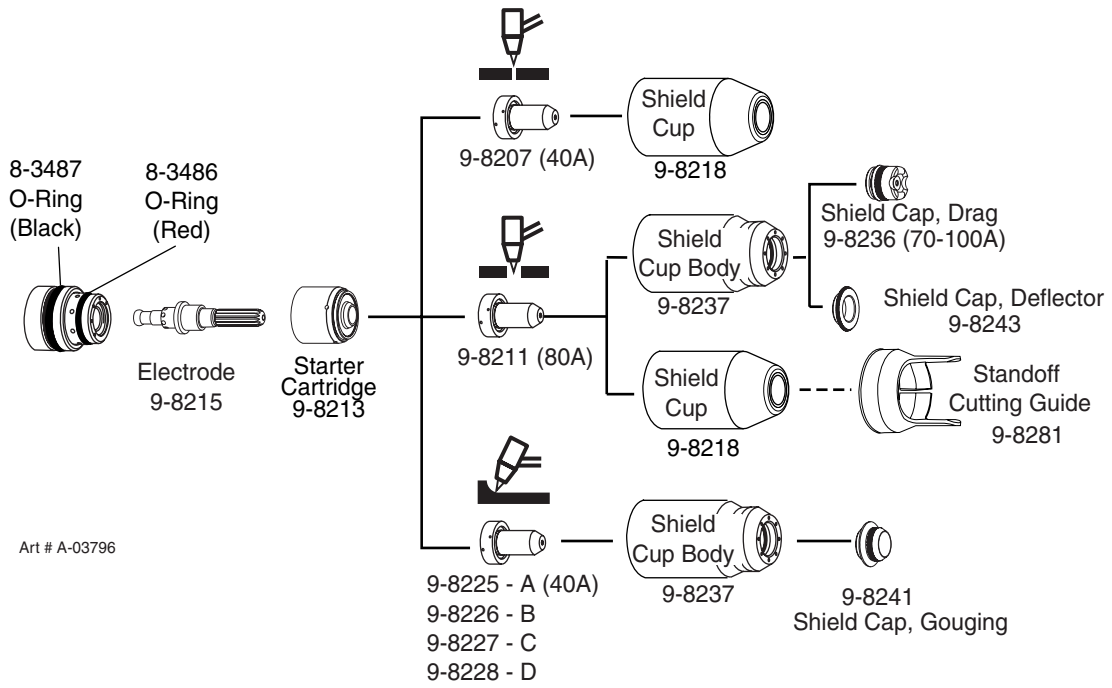

# PATENT INFORMATION

---

The following parts are licensed under U.S. Patent No(s). 5120930 and 5132512

<b>Catalog Number</b>	<b>Description</b>
9-8235	Shield Cap, Drag 50-60A
9-8236	Shield Cap, Drag 70-100A
9-8237	Shield Cup, Body
9-8238	Shield Cap, Machine 50-60A
9-8239	Shield Cap, Machine 70-100A
9-8244	Shield Cap, Drag 40A
9-8245	Shield Cap, Machine 40A



# APPENDIX 1: SEQUENCE OF OPERATION (BLOCK DIAGRAM)

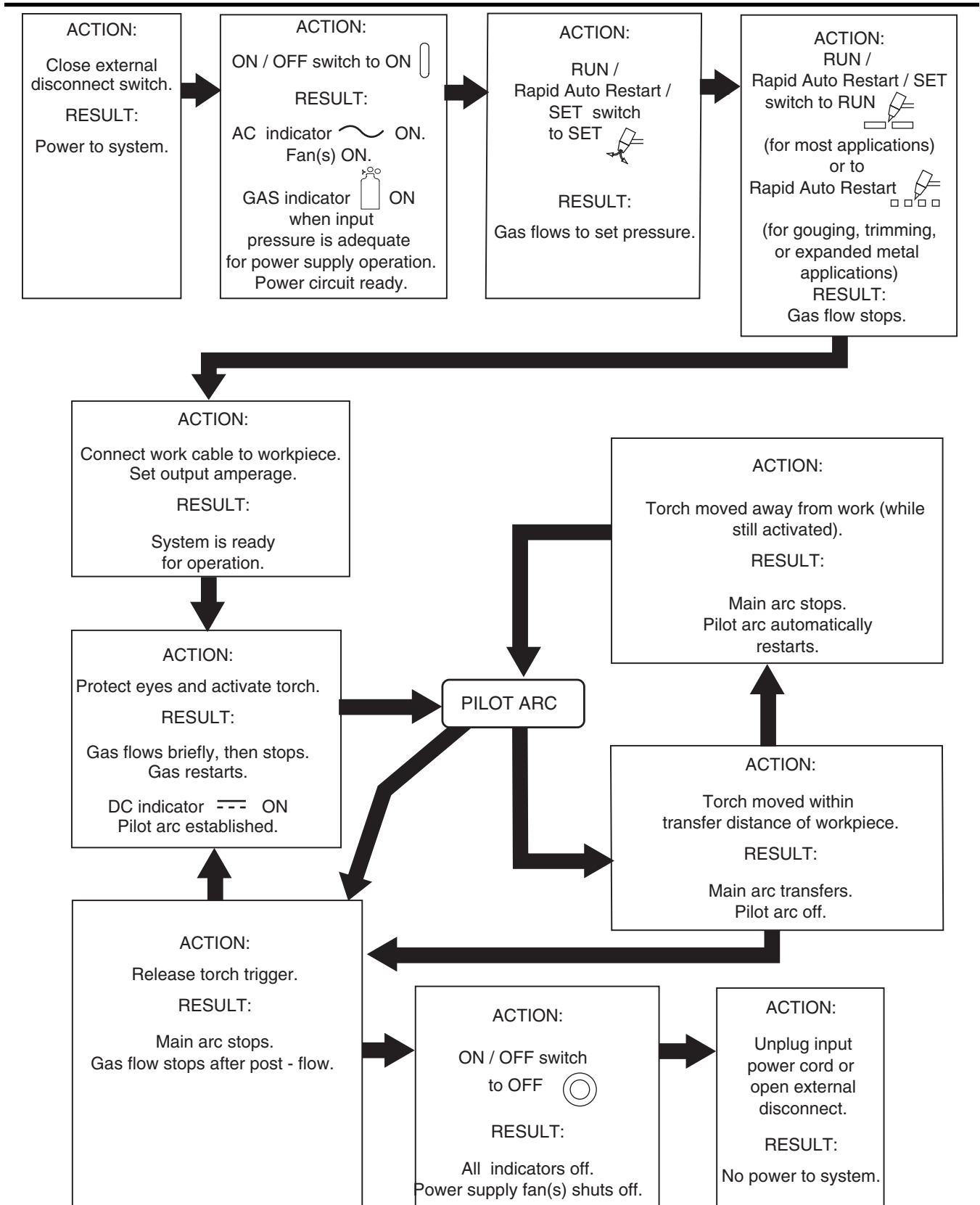

Art #A-03706

# APPENDIX 2: DATA TAG INFORMATION

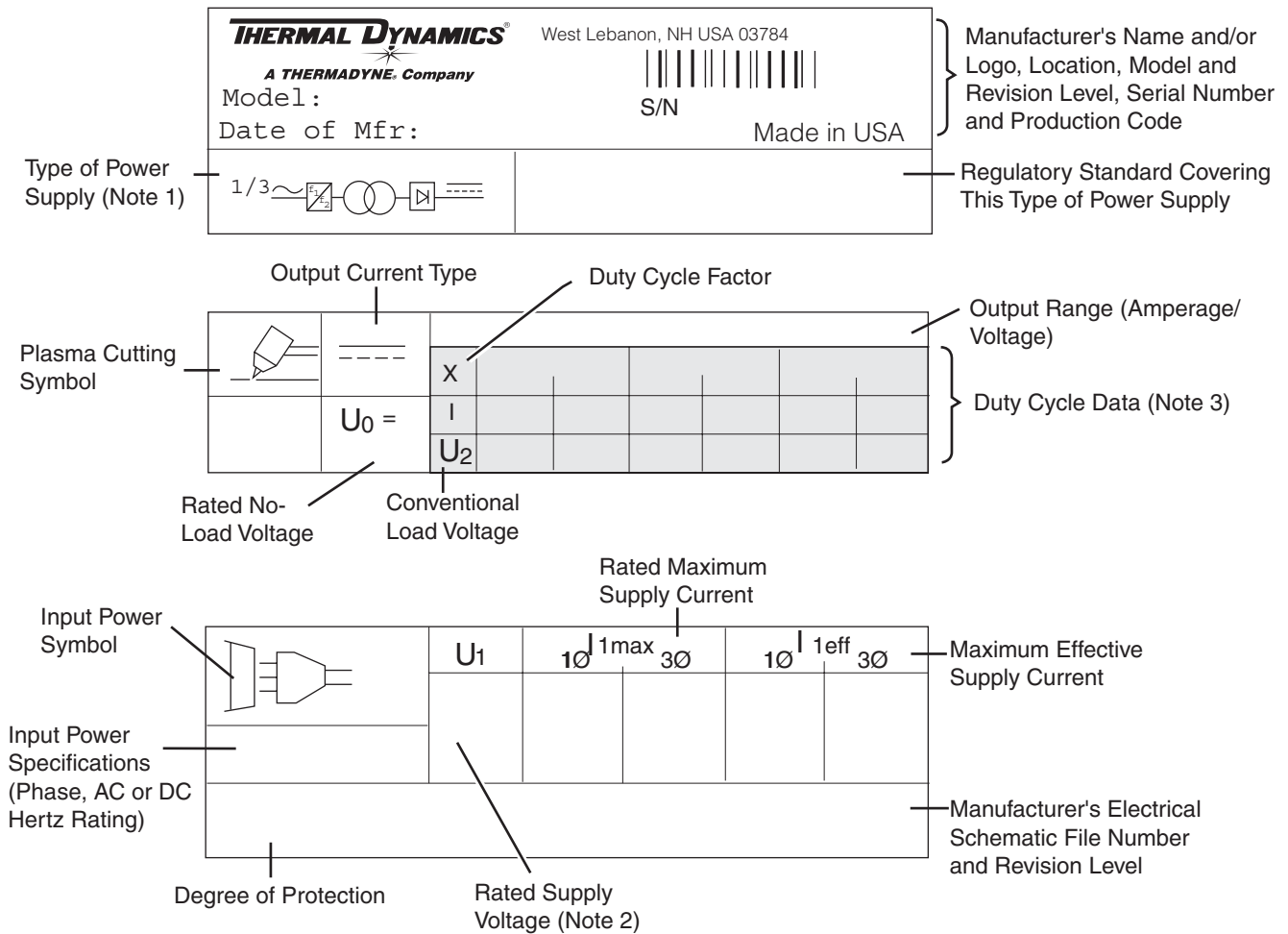

**NOTES:**

- Symbol shown indicates single- or three-phase AC input, static frequency converter-transformer-rectifier, DC output.
- Indicates input voltages for this power supply. Most power supplies carry a label at the input power cord showing input voltage requirements for the power supply as built.
- Top row: Duty cycle values.  
IEC duty cycle value is calculated as specified by the International ElectroTechnical Commission.  
TDC duty cycle value is determined under the power supply manufacturer's test procedures.  
Second row: Rated cutting current values.  
Third row: Conventional load voltage values.
- Sections of the Data Tag may be applied to separate areas of the power supply.

Standard Symbols

- ~ AC
- DC
- ∅ Phase

Art # A-03288

# APPENDIX 3: MAINTENANCE SCHEDULE

---

This schedule applies to all types of *non-liquid cooled* plasma cutting systems. Some systems will not have all the parts listed and those checks need not be performed.

## NOTE

---

*The actual frequency of maintenance may need to be adjusted according to the operating environment.*

### Daily Operational Checks or Every Six Cutting Hours:

1. Check torch consumable parts, replace if damaged or worn.
2. Inspect torch for any cracks or exposed wires, replace if necessary.
3. Check plasma and secondary supply and pressure/flow.
4. Purge plasma gas line to remove any moisture build-up.
5. Inspect input power cable for damage or exposed wires, replace if necessary.

### Weekly or Every 30 Cutting Hours:

1. Check fan for proper operation and adequate air flow.
2. Blow or vacuum dust and dirt *out* of the entire machine.

## CAUTION

---

*Do not blow air into the power supply during cleaning. Blowing air into the unit can cause metal particles to interfere with sensitive electrical components and cause damage to the unit.*

### Six Months or Every 720 Cutting Hours:

1. Check the in-line air filter(s), clean or replace as required
2. Check cables and hoses for leaks or cracks, replace if necessary.
3. Check all contactor points for severe arcing or pits, replace if necessary.

# APPENDIX 4: TORCH PIN - OUT DIAGRAMS

## A. Hand Torch Pin - Out Diagram

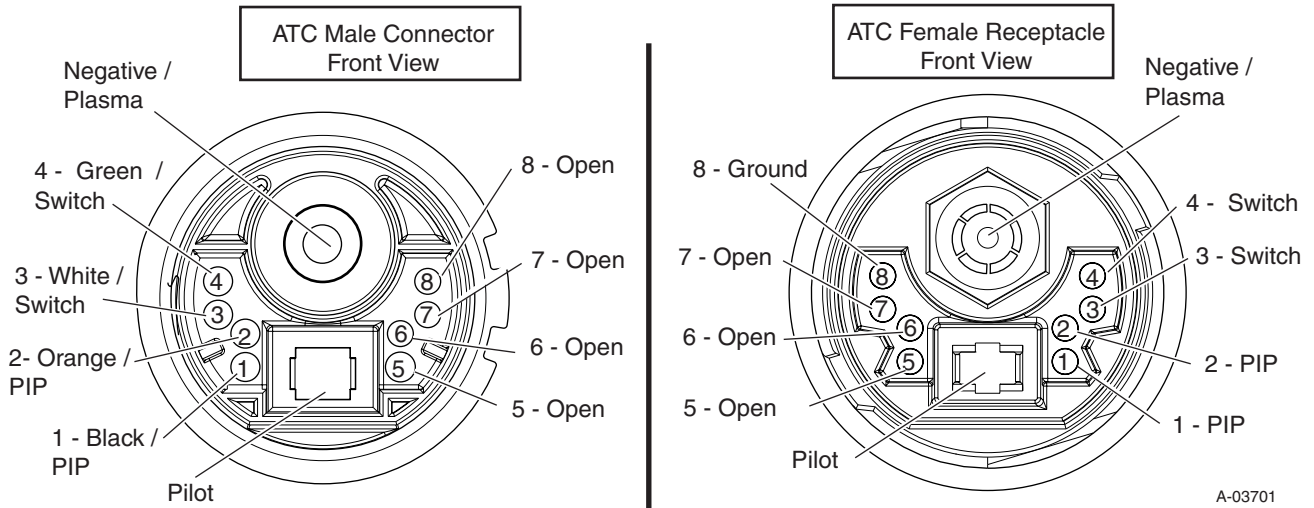

## B. Mechanized (Machine) Torch Pin - Out Diagram

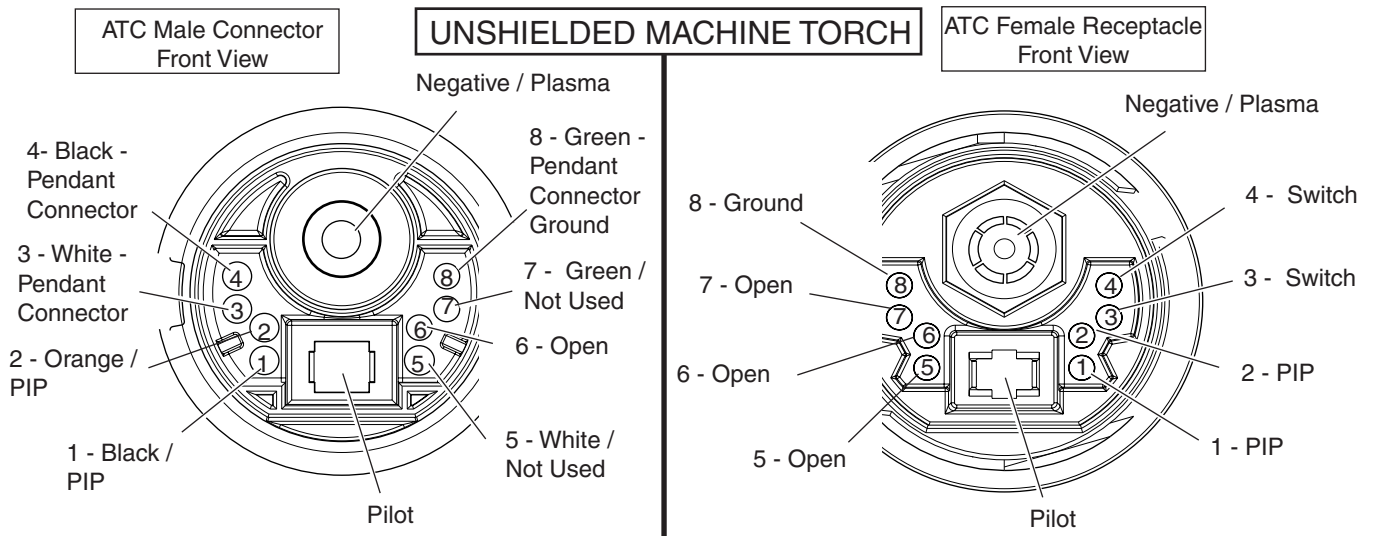

Art # A-03799

# APPENDIX 5: CONNECTION DIAGRAMS

## A. Hand Torch Connection Diagram

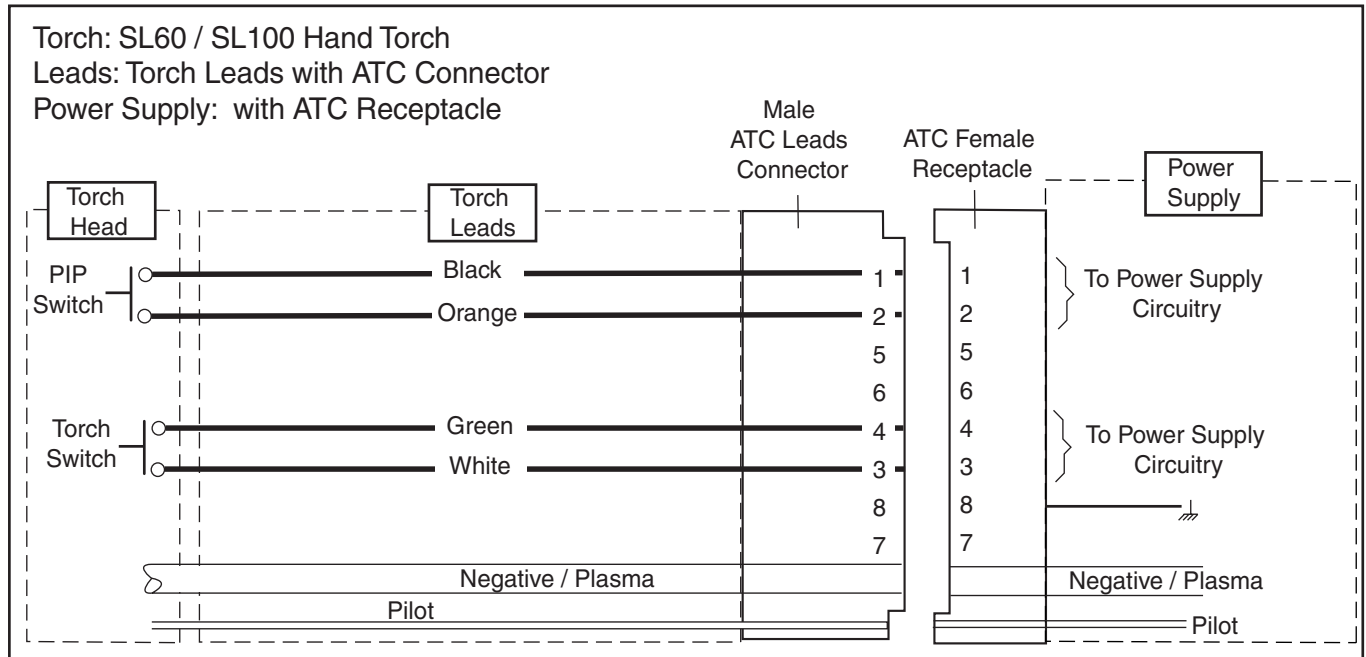

Art # A-03797

## B. Mechanized Torch Connection Diagram

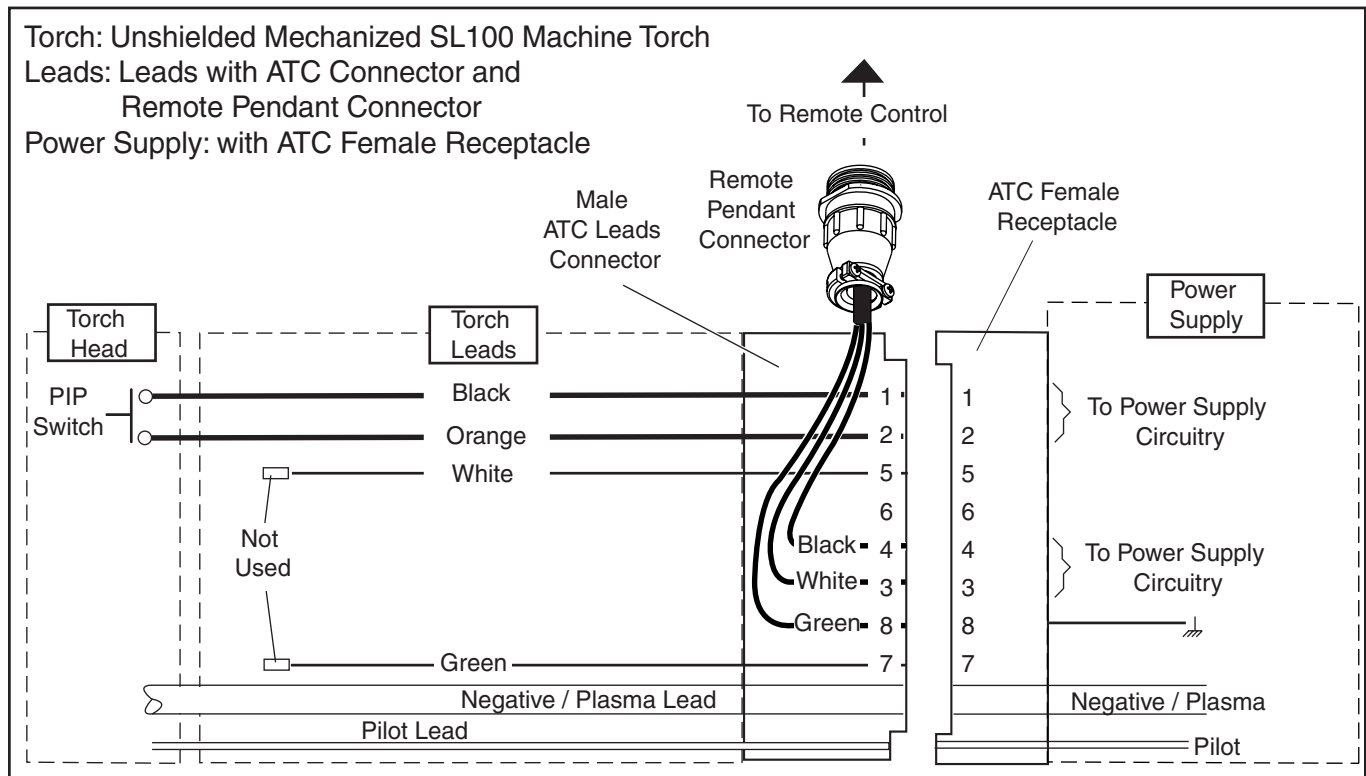

Art # A-03798

# APPENDIX 6: SYSTEM SCHEMATIC, 208/230V UNITS

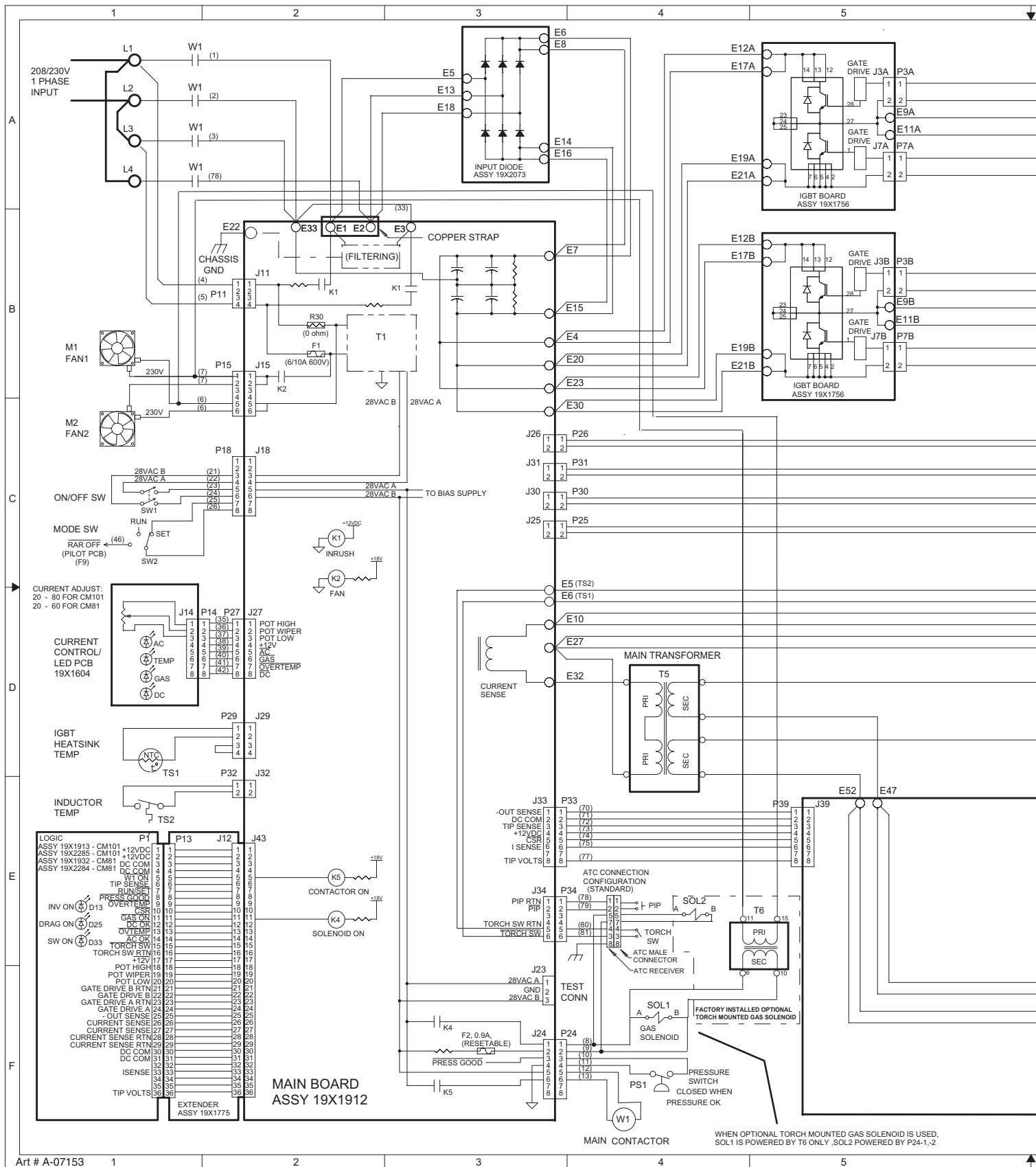

COMP	DESCRIPTION	LOCATION
F1	FUSE, 6/10A 600V KTK	B2
F2	FUSE, 0.9A, RESETTABLE	F3
L1	OUTPUT INDUCTOR	D7
M1	FAN, 4.5" 220VAC	B1
M2	FAN, 4.5" 220VAC	C1
PS1	PRESSURE SWITCH	F4
SOL1	GAS SOLENOID	F4
SW1	SWITCH, ON/OFF	C1
SW2	SWITCH, RUN/SET/RAR	C1
T5	MAIN TRANSFORMER	D4
TS1	TEMP. SENSOR, IGBT HEATSINK	D1
TS2	TEMP. SENSOR, INDUCTOR	E1
W1	MAIN CONTACTOR	F4

NOTES: UNLESS OTHERWISE SPECIFIED -  
1. DEPICTIONS OF CIRCUITRY INSIDE PCB BLOCKS IS FOR REFERENCE ONLY

OPTIONAL AUTOMATION INTERFACE CONNECTIONS

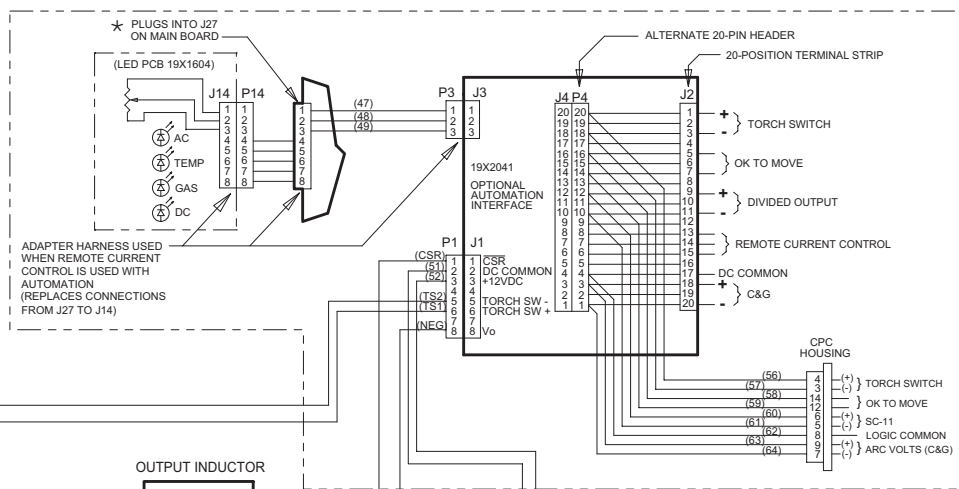

ADAPTER HARNESS USED WHEN REMOTE CURRENT CONTROL IS USED WITH AUTOMATION (REPLACES CONNECTIONS FROM J27 TO J14)

OUTPUT INDUCTOR

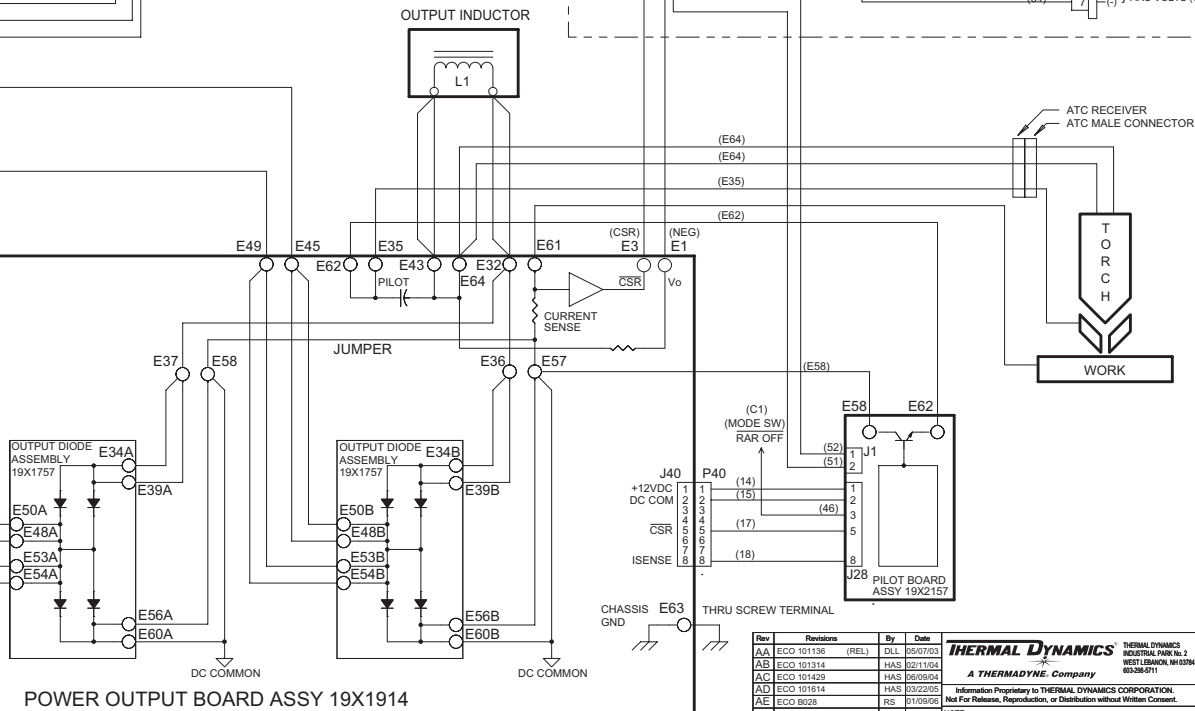
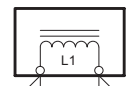

POWER OUTPUT BOARD ASSY 19X1914

Rev	Revisions	By	Date
AA	ECO 101136 (REL)	DLL	05/07/03
AB	ECO 101314	HAS	02/11/04
AC	ECO 101429	HAS	06/09/04
AD	ECO 101614	HAS	03/22/05
AE	ECO 8028	RS	01/09/06
AF	ECO 8016	RWH	01/27/06

**THERMAL DYNAMICS**  
INDUSTRIAL PARK #2  
WEST BAVEN, NJ 07094  
803-268-0711

A THERMADYNE Company

Information Proprietary to THERMAL DYNAMICS CORPORATION.  
Not For Release, Reproduction, or Distribution without Written Consent.

NOTE: Unless Otherwise Specified, Resistors are in Ohms 14W 5%.  
Capacitors are in Microfarads (uF)

TITLE: SCHEMATIC,  
CM81/101 208/230V SYSTEM

PCB No: \_\_\_\_\_  
Asy No: \_\_\_\_\_  
Scale: \_\_\_\_\_  
Supersedes: \_\_\_\_\_  
Date: 05/07/03  
Drawn: D.L.J. | \_\_\_\_\_  
Chk: App: \_\_\_\_\_  
Size: \_\_\_\_\_ | Sheet 1 of 1  
DWG No: D 42X1136

Last Modified: Friday, January 27, 2006 11:06:29

# APPENDIX 7: SYSTEM SCHEMATIC, 400-460V UNITS

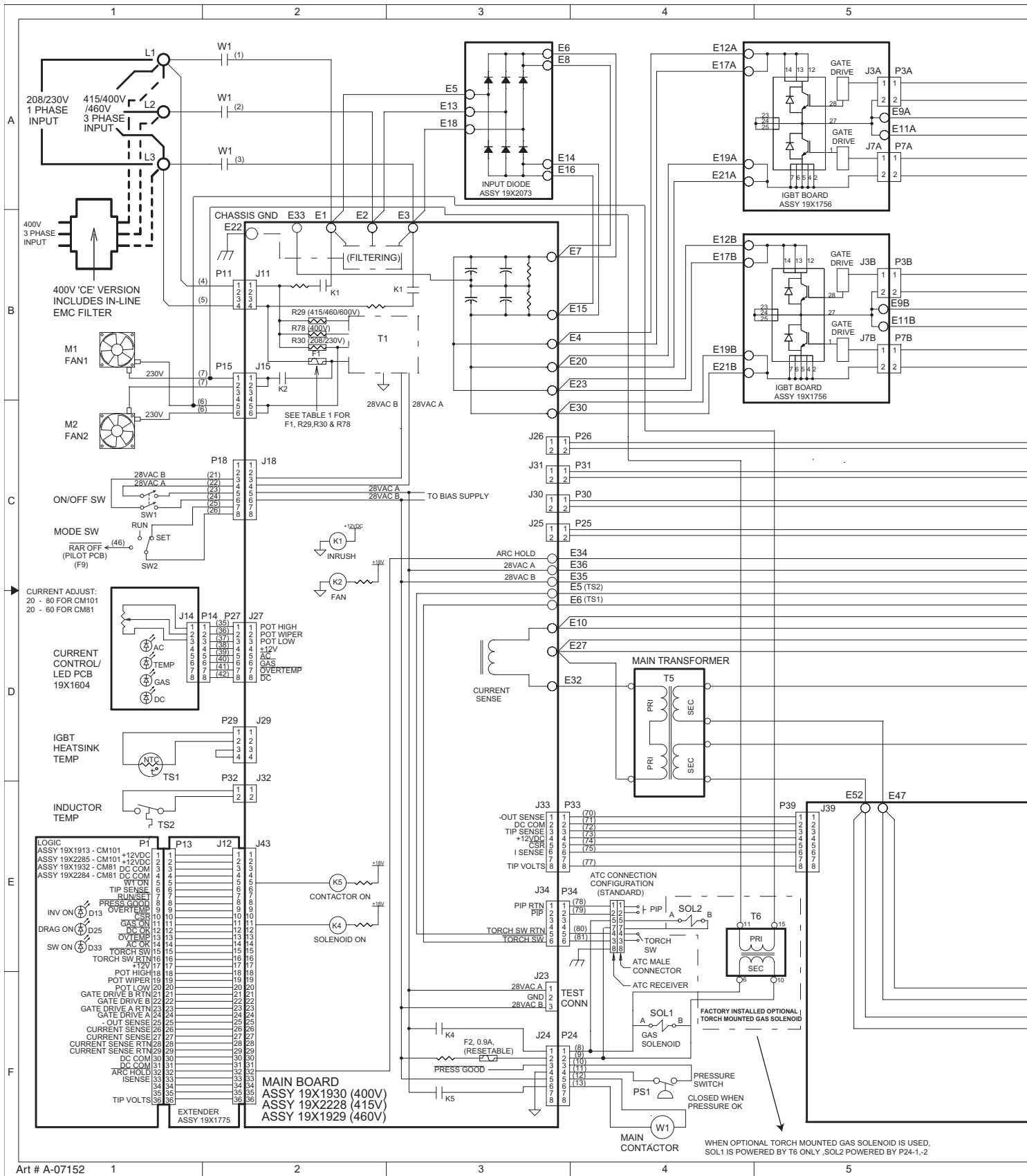



TABLE 1

	19X1930 400V	19X2228 415V	19X1929 460V
R78	ZERO-OHM 115X465-2	X X X X X	X X X X X
R29	X X X X X	ZERO-OHM 115X465-2	ZERO-OHM 115X465-2
R30	X X X X X	X X X X X	X X X X X
F1	4/10, 500V 21X186	4/10, 500V 21X186	1/4A, 500V 21X183

COMP	DESCRIPTION	LOCATION
F1	SEE CHART 1	B2
F2	0.9A, (RESETABLE)	F3
L1	OUTPUT INDUCTOR	D7
M1	FAN, 4.5" 220VAC	B1
M2	FAN, 4.5" 220VAC	C1
PS1	PRESSURE SWITCH	F4
SOL1	GAS SOLENOID	F4
SW1	SWITCH, ON/OFF	C1
SW2	SWITCH, RUN/SET/RAR	C1
T5	MAIN TRANSFORMER	D4
TS1	TEMP. SENSOR, IGBT HEATSINK	D1
TS2	TEMP. SENSOR, INDUCTOR	E1
W1	MAIN CONTACTOR	F4

NOTES: UNLESS OTHERWISE SPECIFIED -  
1. DEPICTIONS OF CIRCUITRY INSIDE PCB BLOCKS IS FOR REFERENCE ONLY

OPTIONAL AUTOMATION INTERFACE CONNECTIONS

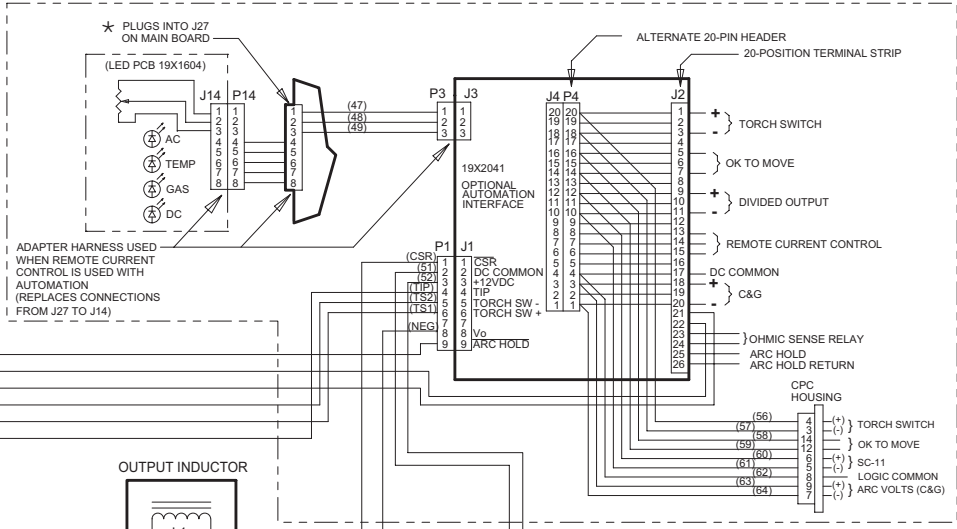

OUTPUT INDUCTOR

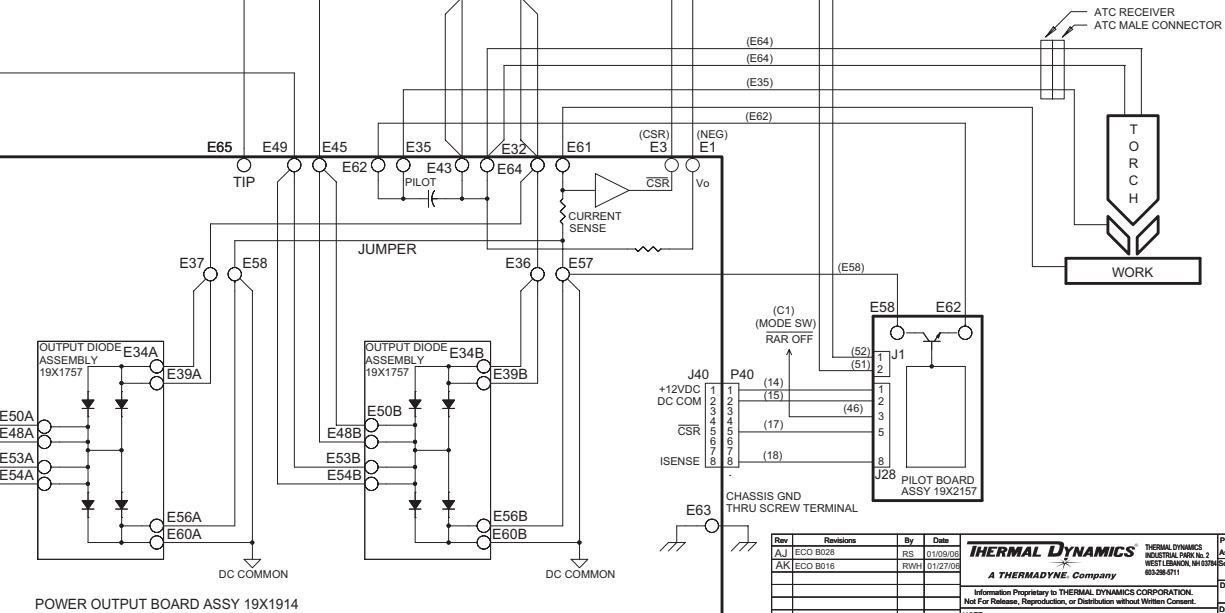

Rev	Revisions	By	Date
AJ	ECC B028	RS	01/09/08
AK	ECC B016	RWH	01/27/08

**THERMAL DYNAMICS**  
A THERMADYNE Company

Information Proprietary to THERMAL DYNAMICS CORPORATION.  
Not For Release, Reproduction, or Distribution without Written Consent.

NOTE: Unless Otherwise Specified, Resistors are in Ohms 1/4W 5%.  
Capacitors are in Microfarads (uF)

DATE: 05/07/03  
DRAWN: 011j  
REFERENCES: 011j  
SCALE: 1:1  
SHEET: 1 of 1  
DWG No: 42X1135

TITLE: SCHEMATIC, CM81/101 400/415/460V SYSTEM

Last Modified: Friday, January 27, 2008

# APPENDIX 8: SYSTEM SCHEMATIC, 600V UNITS

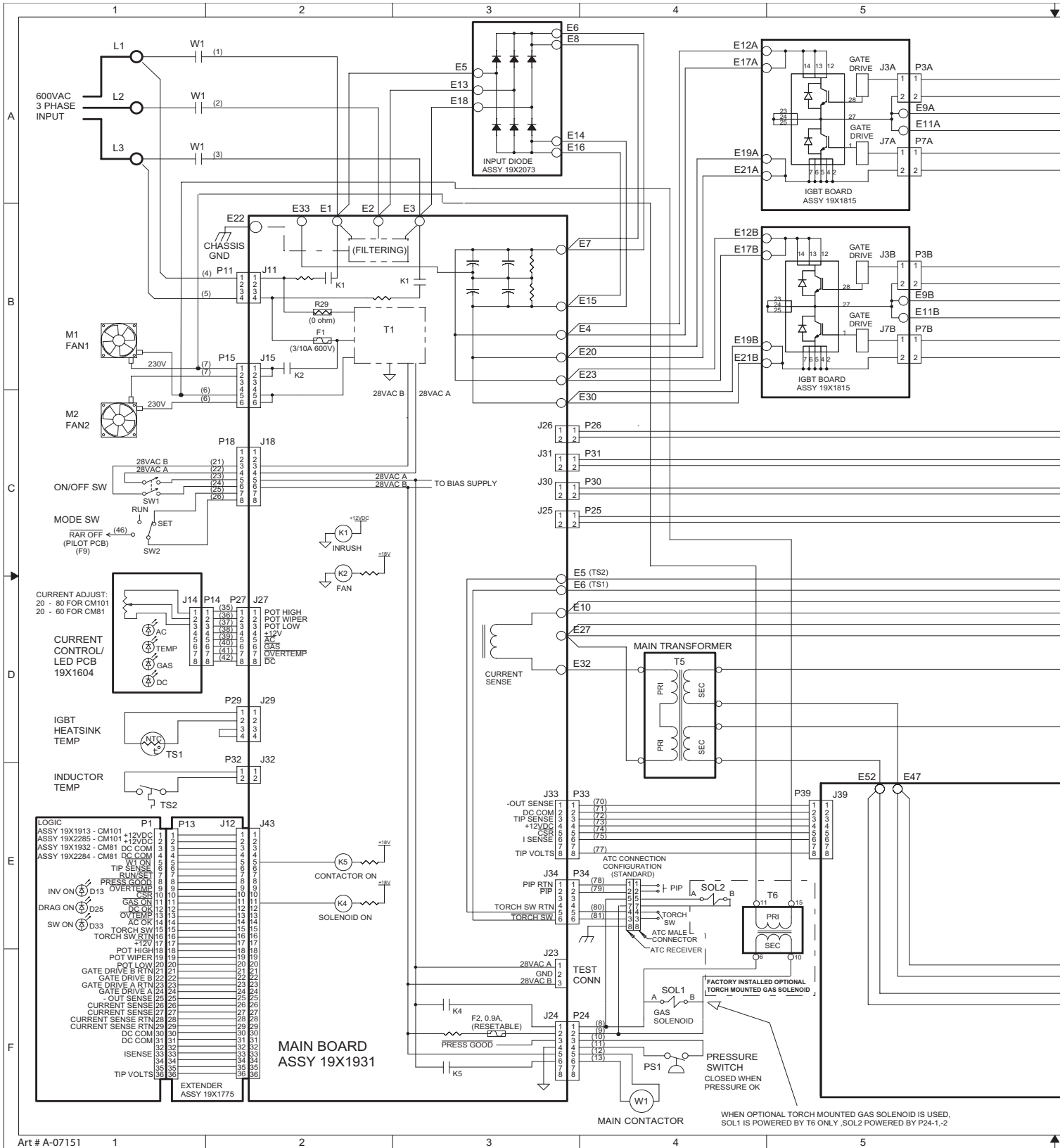

6 7 8 9 10

COMP	DESCRIPTION	LOCATION
F1	FUSE, 3/10A 600V FNG-R	B2
F2	FUSE, 0.9A, RESETTABLE	F3
L1	OUTPUT INDUCTOR	D7
M1	FAN, 4.5" 220VAC	B1
M2	FAN, 4.5" 220VAC	C1
PS1	PRESSURE SWITCH	F4
SOL1	GAS SOLENOID	F4
SW1	SWITCH, ON/OFF	C1
SW2	SWITCH, RUN/SET/RAR	C1
TS	MAIN TRANSFORMER	D4
TS1	TEMP. SENSOR, IGBT HEATSINK	D1
TS2	TEMP. SENSOR, INDUCTOR	E1
W1	MAIN CONTACTOR	F4

NOTES: UNLESS OTHERWISE SPECIFIED -  
1. DEPICTIONS OF CIRCUITRY INSIDE PCB BLOCKS IS FOR REFERENCE ONLY

OPTIONAL AUTOMATION INTERFACE CONNECTIONS

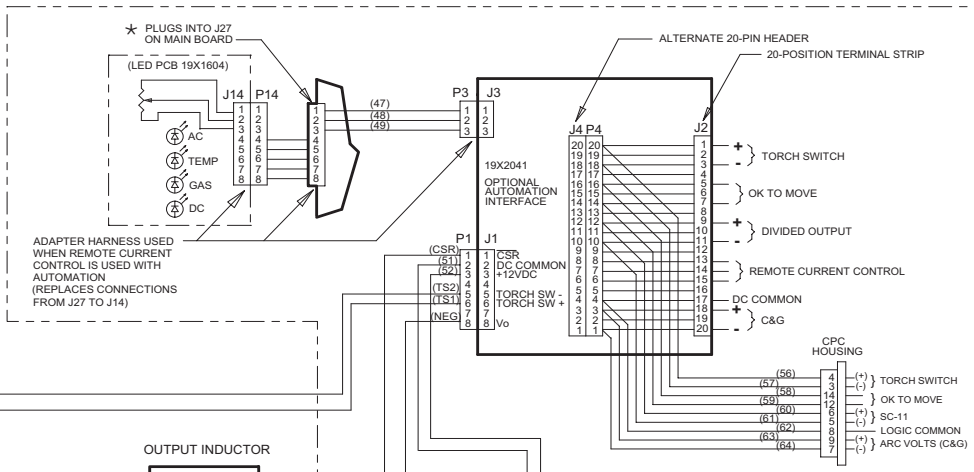

OUTPUT INDUCTOR

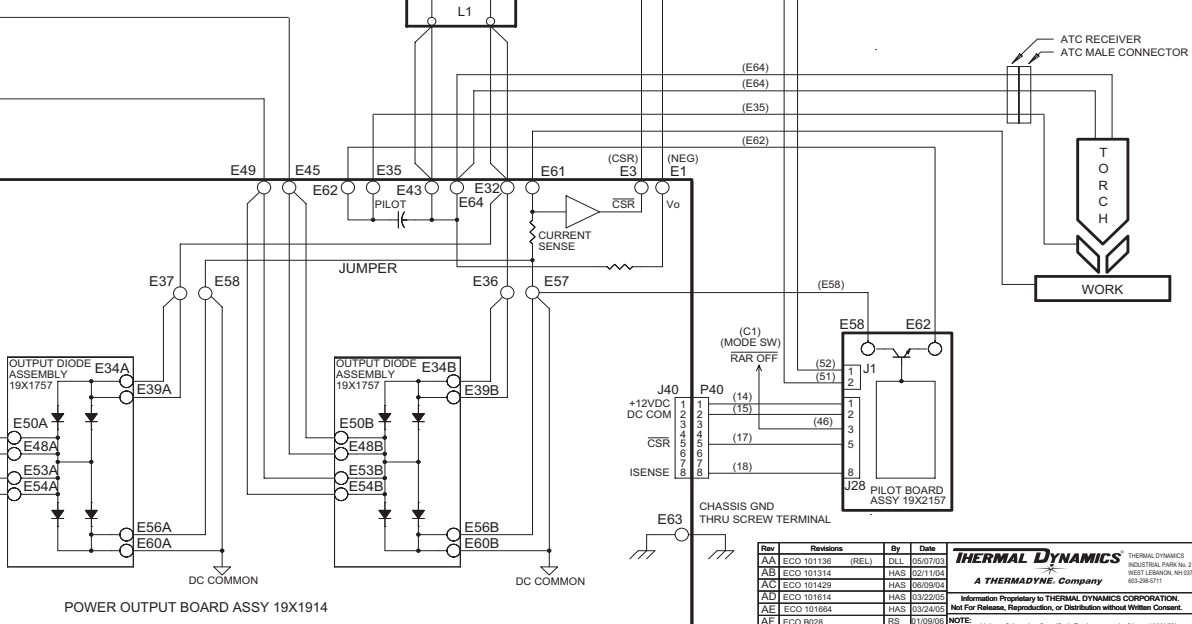
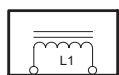

Rev	Revisions	By	Date
AA	ECO 101136 (REL)	DLL	05/07/03
AB	ECO 101314	HAS	02/11/04
AC	ECO 101429	HAS	06/59/04
AD	ECO 101614	HAS	03/22/05
AE	ECO 101664	HAS	03/24/05
AF	ECO 8928	RS	01/08/05
AG	ECO 8016	RWH	01/22/06
AH	ECO 8077	RWH	07/31/06

**THERMAL DYNAMICS**  
 A THERMADYNE Company  
 INFORMATION PROPRIETARY TO THERMAL DYNAMICS CORPORATION. NOT FOR RELEASE, REPRODUCTION, OR DISTRIBUTION WITHOUT WRITTEN CONSENT.  
 NOTE: Unless Otherwise Specified, Resistors are in Ohms 1/4W 5%. Capacitors are in Microfarads (uF).

PCB No: \_\_\_\_\_  
 Assy No: \_\_\_\_\_  
 Scale: \_\_\_\_\_  
 Date: 05/07/03  
 Drawn: DJJ  
 Ck: Wpp  
 Sheet 1 of 1  
 Title: SCHEMATIC, CM81/101 600V 3PH SYSTEM  
 Size: D  
 DWG No: 42X1134

Last Modified: Friday, January 27, 2006

6 7 8 9 10 Art # A-07151

## APPENDIX 9: Publication History

---

<u>Date</u>	<u>Revision</u>	<u>Comments</u>
6/3/2003	-	Manual released.
7/18/03	-	Added 600V units per ECO 100979.
12/5/03	-	Updated w/ new schematics & input from Sales/Tech Service
1/5/04	-	Updated gas pressures & flows.
1/16/04	-	Updated warranty statement & system schematics, misc minor edits.
2/9/04	-	Deleted system schematics.
2/12/04	-	Inserted corrected system schematics.
6/23/04	-	Updated system schematics per ECO 101429.
9/21/05	-	Updated system schematics and art work for new work-lead clamp
2/17/06	-	Updated system schematics per ECO B033.
9/29/06	AA.01	Added Patent information and new Rev. AA.01. Updated format of manual.
3/14/07	AB.01	Updated 600 volt schematic to show new fuse.

---

### NOTE

*Thermal Dynamics uses the manual cover date to indicate manual revision level.*



## Global Customer Service Contact Information

### **Thermadyne USA**

2800 Airport Road  
Denton, Tx 76207 USA  
Telephone: (940) 566-2000  
800-426-1888  
Fax: 800-535-0557  
Email: sales@thermaldarc.com

### **Thermadyne Victor Brasil**

Avenida Brasil  
13629-Cordovil  
Rio de Janeiro, Brazil 21012-351  
Telephone: 55-21-2485-8998  
Fax: 55-21-2-485-8735

### **Thermadyne Canada**

2070 Wyecroft Road  
Oakville, Ontario  
Canada, L6L5V6  
Telephone: (905)-827-1111  
Fax: 905-827-3648

### **Thermadyne Chile**

Piloto Lazo #90  
Cerrillos  
Santiago, Chile 7278-654  
Telephone: 56-2-557-2465  
Fax: 56-2-557-5349

### **Thermadyne Europe**

Europe Building  
Chorley North Industrial Park  
Chorley, Lancashire  
England, PR6 7Bx  
Telephone: 44-1257-261755  
Fax: 44-1257-224800

### **Thermadyne, China**

RM 102A  
685 Ding Xi Rd  
Chang Ning District  
Shanghai, PR, 200052  
Telephone: 86-21-69171135  
Fax: 86-21-69171139

### **Thermadyne Asia Sdn Bhd**

Lot 151, Jalan Industri 3/5A  
Rawang Integrated Industrial Park - Jln Batu Arang  
48000 Rawang Selangor Darul Ehsan  
West Malaysia  
Telephone: 603+ 6092 2988  
Fax : 603+ 6092 1085

### **Cigweld, Australia**

71 Gower Street  
Preston, Victoria  
Australia, 3072  
Telephone: 61-3-9474-7400  
Fax: 61-3-9474-7510

### **Thermadyne Italy**

OCIM, S.r.L.  
Via Benaco, 3  
20098 S. Giuliano  
Milan, Italy  
Tel: (39) 02-98 80320  
Fax: (39) 02-98 281773

### **Thermadyne South Africa**

209 Risi Ave.  
Linmeyer  
Johannesberg, 2197  
South Africa  
Tel: (27) 11-917 3600  
Fax: (27) 11-917 8580

### **Thermadyne International**

2070 Wyecroft Road  
Oakville, Ontario  
Canada, L6L5V6  
Telephone: (905)-827-9777  
Fax: 905-827-9797

---

**Corporate Headquarters**

16052 Swingley Ridge Road

Suite 300

St. Louis, MO 63017

Telephone: 636-728-3000

Email: [TDCSales@Thermadyne.com](mailto:TDCSales@Thermadyne.com)

[www.thermadyne.com](http://www.thermadyne.com)

***THERMAL DYNAMICS***  
