

powermax1000[®]

Plasma Arc Cutting System

***Operator Manual
804290 Revision 0***

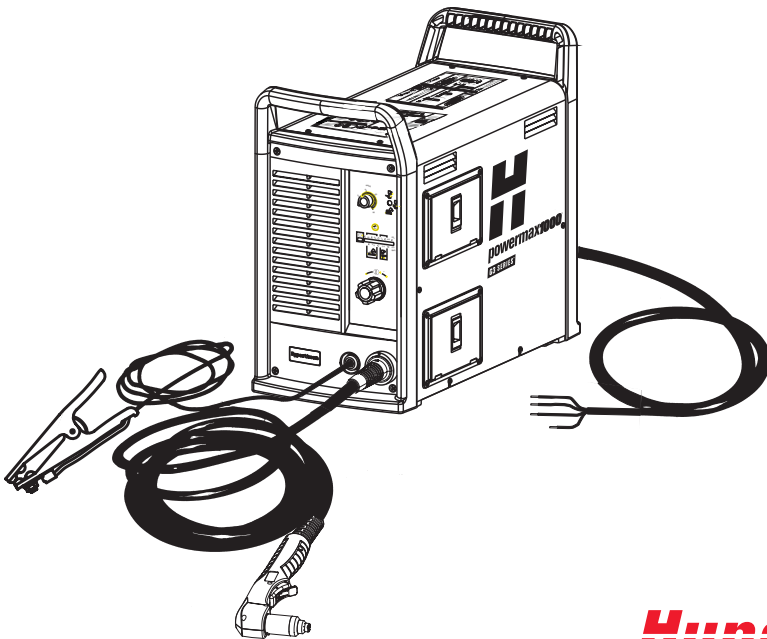

Hypertherm[®]

*The world leader in
plasma cutting technology™*

powermax1000

Operator Manual

(P/N 804290)

Revision 0 – September 2001

**Hypertherm, Inc.
Hanover, NH USA**

www.hypertherm.com

© Copyright 2001 Hypertherm, Inc.
All Rights Reserved

Hypertherm and powermax are trademarks of Hypertherm, Inc.
and may be registered in the United States and/or other countries.

Hypertherm, Inc.

Etna Road, P.O. Box 5010
Hanover, NH 03755 USA
603-643-3441 Tel (Main Office)
603-643-5352 Fax (All Departments)
800-643-9878 Tel (Technical Service)
800-737-2978 Tel (Customer Service)

Hypertherm Automation, LLC

5 Technology Drive
West Lebanon, NH 03755 USA
603-298-7970 Tel
603-298-7977 Fax

Hypertherm Plasmatechnik, GmbH

Technologiepark Hanau
Rodenbacher Chaussee 6
63457 Hanau-Wolfgang, Germany
49 6181 58 2100 Tel
49 6181 58 2134 Fax
49 6181 58 2123 (Technical Service)

Hypertherm (S) Pte Ltd

No. 19 Kaki Bukit Road 2
K.B. Warehouse Complex
Singapore 417847, Republic of Singapore
65 6 841 2489 Tel
65 6 841 2490 Fax
65 6 841 2489 (Technical Service)

Japan

1952-14 Yata-Natsumegi
Mishima City, Shizuoka Pref.
411-0801 Japan
81 0 559 75 7387 Tel
81 0 559 75 7376 Fax

Hypertherm UK, Ltd

9 Berkeley Court, Manor Park
Runcorn, Cheshire, England WA7 1TQ
44 1928 579 074 Tel
44 1928 579 604 Fax

France

15 Impasse des Rosiers
95610 Eragny, France
00 800 3324 9737 Tel
00 800 4973 7329 Fax

Hypertherm S.r.l.

Via Torino 2
20123 Milano, Italia
39 02 725 46 312 Tel
39 02 725 46 400 Fax
39 02 725 46 314 (Technical Service)

Hypertherm Europe B.V.

Vaartveld 9
4704 SE Roosendaal, Nederland
31 165 596908 Tel
31 165 596901 Fax

Technical Service:

00 800 49 73 7843 – toll-free in Europe

31 165 596900 Tel

Hypertherm Brasil Ltda.

Rua Visconde de Santa Isabel, 20 – Sala 611
Vila Isabel, RJ
Brasil CEP 20560-120
55 21 2278 6162 Tel
55 21 2578 0947 Fax

EMC INTRODUCTION

Hypertherm's CE-marked equipment is built in compliance with standard EN50199. The equipment should be installed and used in accordance with the information below to achieve electromagnetic compatibility.

The limits required by EN50199 may not be adequate to completely eliminate interference when the affected equipment is in close proximity or has a high degree of sensitivity. In such cases it may be necessary to use other measures to further reduce interference.

This plasma equipment is designed for use only in an industrial environment.

INSTALLATION AND USE

The user is responsible for installing and using the plasma equipment according to the manufacturer's instructions. If electromagnetic disturbances are detected then it shall be the responsibility of the user to resolve the situation with the technical assistance of the manufacturer. In some cases this remedial action may be as simple as earthing the cutting circuit, see *Earthing of Workpiece*. In other cases it could involve constructing an electromagnetic screen enclosing the power source and the work complete with associated input filters. In all cases electromagnetic disturbances must be reduced to the point where they are no longer troublesome.

ASSESSMENT OF AREA

Before installing the equipment the user shall make an assessment of potential electromagnetic problems in the surrounding area. The following shall be taken into account:

- a. Other supply cables, control cables, signalling and telephone cables; above, below and adjacent to the cutting equipment.
- b. Radio and television transmitters and receivers.
- c. Computer and other control equipment.
- d. Safety critical equipment, for example guarding of industrial equipment.
- e. Health of the people around, for example the use of pacemakers and hearing aids.
- f. Equipment used for calibration or measurement.
- g. Immunity of other equipment in the environment. User shall ensure that other equipment being used in the environment is compatible. This may require additional protection measures.

h. Time of day that cutting or other activities are to be carried out.

The size of the surrounding area to be considered will depend on the structure of the building and other activities that are taking place. The surrounding area may extend beyond the boundaries of the premises.

METHODS OF REDUCING EMISSIONS

Mains Supply

Cutting equipment must be connected to the mains supply according to the manufacturer's recommendations. If interference occurs, it may be necessary to take additional precautions such as filtering of the mains supply. Consideration should be given to shielding the supply cable of permanently installed cutting equipment, in metallic conduit or equivalent. Shielding should be electrically continuous throughout its length. The shielding should be connected to the cutting mains supply so that good electrical contact is maintained between the conduit and the cutting power source enclosure.

Maintenance of Cutting Equipment

The cutting equipment must be routinely maintained according to the manufacturer's recommendations. All access and service doors and covers should be closed and properly fastened when the cutting equipment is in operation. The cutting equipment should not be modified in any way except for those changes and adjustments covered in the manufacturer's instructions. In particular, the spark gaps of arc striking and stabilizing devices should be adjusted and maintained according to the manufacturer's recommendations.

Cutting Cables

The cutting cables should be kept as short as possible and should be positioned close together, running at or close to the floor level.

Equipotential Bonding

Bonding of all metallic components in the cutting installation and adjacent to it should be considered. However, metallic components bonded to the workpiece will increase the risk that the operator could receive a shock by touching these metallic compo-

nents and the electrode at the same time. The operator should be insulated from all such bonded metallic components.

Earthing of Workpiece

Where the workpiece is not bonded to earth for electrical safety, nor connected to earth because of its size and position, for example, ship's hull or building steelwork, a connection bonding the workpiece to earth may reduce emissions in some, but not all instances. Care should be taken to prevent the earthing of the workpiece increasing the risk of injury to users, or damage to other electrical equipment. Where necessary, the connection of the workpiece to earth should be made by a direct connection to the workpiece, but in some countries where direct connection is not permitted, the bonding should be achieved by suitable capacitances selected according to national regulations.

Note. The cutting circuit may or may not be earthed for safety reasons. Changing the earthing arrangements should only be authorized by a person who is competent to assess whether the changes will increase the risk of injury, for example, by allowing parallel cutting current return paths which may damage the earth circuits of other equipment. Further guidance is given in IEC TC26 (sec)94 and IEC TC26/108A/CD Arc Welding Equipment Installation and Use.

Screening and Shielding

Selective screening and shielding of other cables and equipment in the surrounding area may alleviate problems of interference. Screening of the entire plasma cutting installation may be considered for special applications

WARRANTY

WARNING

Genuine Hypertherm parts are the factory-recommended replacement parts for your Hypertherm system. Any damage caused by the use of other than genuine Hypertherm parts may not be covered by the Hypertherm warranty.

WARNING

You are responsible for the safe use of the Product. Hypertherm does not and cannot make any guarantee or warranty regarding the safe use of the Product in your environment.

GENERAL

Hypertherm, Inc. warrants that its Products shall be free from defects in materials and workmanship, if Hypertherm is notified of a defect (i) with respect to the power supply within a period of two (2) years from the date of its delivery to you, with the exception of G3 Series power supplies, which shall be within a period of three (3) years from the date of delivery to you, and (ii) with respect to the torch and leads within a period of one (1) year from its date of delivery to you. This warranty shall not apply to any Product which has been incorrectly installed, modified, or otherwise damaged. Hypertherm, at its sole option, shall repair, replace, or adjust, free of charge, any defective Products covered by this warranty which shall be returned with Hypertherm's prior authorization (which shall not be unreasonably withheld), properly packed, to Hypertherm's place of business in Hanover, New Hampshire, or to an authorized Hypertherm repair facility, all costs, insurance and freight prepaid. Hypertherm shall not be liable for any repairs, replacement, or adjustments of Products covered by this warranty, except those made pursuant to this paragraph or with Hypertherm's prior written consent. **The warranty above is exclusive and is in lieu of all other warranties, express, implied, statutory, or otherwise with respect to the Products or as to the results which may be obtained therefrom, and all implied warranties or conditions of quality or of merchantability or fitness for a particular purpose or against infringement. The foregoing shall constitute the sole and exclusive remedy for any breach by Hypertherm of its warranty.** Distributors/OEMs may offer different or additional warranties, but Distributors/OEMs are not authorized to give any additional warranty protection to you or make any representation to you purporting to be binding upon Hypertherm.

PATENT INDEMNITY

Except only in cases of products not manufactured by Hypertherm or manufactured by a person other than Hypertherm not in strict conformity with Hypertherm's specifications and in cases of designs, processes,

formulae, or combinations not developed or purported to be developed by Hypertherm, Hypertherm will defend or settle, at its own expense, any suit or proceeding brought against you alleging that the use of the Hypertherm product, alone and not in combination with any other product not supplied by Hypertherm, infringes any patent of any third party. You shall notify Hypertherm promptly upon learning of any action or threatened action in connection with any such alleged infringement, and Hypertherm's obligation to indemnify shall be conditioned upon Hypertherm's sole control of, and the indemnified party's cooperation and assistance in, the defense of the claim.

LIMITATION OF LIABILITY

In no event shall Hypertherm be liable to any person or entity for any incidental, consequential, indirect, or punitive damages (including but not limited to lost profits) regardless of whether such liability is based on breach of contract, tort, strict liability, breach of warranties, failure of essential purpose or otherwise and even if advised of the possibility of such damages.

LIABILITY CAP

In no event shall Hypertherm's liability, whether such liability is based on breach of contract, tort, strict liability, breach of warranties, failure of essential purpose or otherwise, for any claim action suit or proceeding arising out of or relating to the use of the Products exceed in the aggregate the amount paid for the Products that gave rise to such claim.

INSURANCE

At all times you will have and maintain insurance in such quantities and types, and with coverage sufficient and appropriate to defend and to hold Hypertherm harmless in the event of any cause of action arising from the use of the Products.

NATIONAL AND LOCAL CODES

National and Local codes governing plumbing and electrical installation shall take precedent over any instructions contained in this manual. **In no event** shall Hypertherm be liable for injury to persons or property damage by reason of any code violation or poor work practices.

TRANSFER OF RIGHTS

You may transfer any remaining rights you may have hereunder only in connection with the sale of all or substantially all of your assets or capital stock to a successor in interest who agrees to be bound by all of the terms and conditions of this Warranty.

Electromagnetic Compatibilityi
 Warrantyii

Section 1 Safety

Recognize Safety Information 1-2
 Follow Safety Instructions 1-2
 Cutting Can Cause Fire or Explosion 1-2
 Electric Shock Can Kill 1-3
 Cutting Can Produce Toxic Fumes 1-3
 A Plasma Arc Can Cause Injury and Burns 1-4
 Arc Rays Can Burn Eyes and Skin 1-4
 Grounding Safety 1-4
 Compressed Gas Equipment Safety 1-5
 Gas Cylinders Can Explode If Damaged 1-5
 Noise Can Damage Hearing 1-5
 Pacemaker and Hearing Aid Operation 1-5
 A Plasma Arc Can Damage Frozen Pipes 1-5
 Additional Safety Information 1-5
 Warning Label 1-6

Section 1a Sécurité

Identifier les consignes de sécurité 1a-2
 Suivre les instructions de sécurité 1a-2
 Danger Avertissement Précaution 1a-2
 Le coupage peut provoquer un incendie ou une explosion 1a-2
 Prévention des incendies, Prévention des explosions 1a-2
 Risque d'explosion argon-hydrogène et méthane 1a-2
 Détonation de l'hydrogène lors du coupage de l'aluminium 1a-2
 Les chocs électriques peuvent être fatals 1a-3
 Prévention des chocs électriques 1a-3
 Le coupage peut produire des vapeurs toxiques 1a-3
 L'arc plasma peut provoquer des blessures ou des brûlures 1a-4
 Torches à allumage instantané 1a-4
 Les rayons de l'arc peuvent brûler les yeux et la peau 1a-4
 Protection des yeux, Protection de la peau, Zone de coupage 1a-4
 Mise à la masse et à la terre 1a-4
 Câble de retour, Table de travail, Alimentation 1a-4
 Sécurité des bouteilles de gaz comprimé 1a-5
 Les bouteilles de gaz comprimé peuvent exploser en cas de dommages 1a-5
 Le bruit peut provoquer des problèmes auditifs 1a-5
 Pacemakers et prothèses auditives 1a-5
 Un arc plasma peut endommager les tuyaux gelés 1a-5
 Étiquette de sécurité 1a-6

Section 2 Specifications

Specifications – Power Supply 2-2
 Power Supply – Dimensions and Weight 2-3
 Specifications – T60 Torches 2-4

TABLE OF CONTENTS

Torch Dimensions.....	2-5
Symbols and Markings.....	2-6
Section 3 Setup	
Upon Receipt.....	3-2
Claims.....	3-2
Contents of Box.....	3-2
Locating Power Supply.....	3-2
Lifting Power Supply.....	3-3
Power Connection.....	3-4
Three Phase Power Cord – Plug Installation.....	3-4
Single Phase Power Cord.....	3-5
Power Cord Installation.....	3-5
Plug Installation.....	3-5
Grounding.....	3-6
Extension Cords.....	3-6
Torch Installation.....	3-7
Plasma Gas Supply.....	3-9
Additional Gas Filtration.....	3-9
Gas Supply Installation.....	3-10
T60M Torch Alignment.....	3-10
ON/OFF Pendant Connection.....	3-11
Machine Interface Connection.....	3-11
Arc Voltage.....	3-12
Changing XFER (start machine motion) from dry contact closure to voltage signal.....	3-14
Section 4 Operation	
Controls and Indicators.....	4-2
Indicator LEDs.....	4-2
Torch Consumable Configurations.....	4-3
Installing Torch Consumables.....	4-4
Mode Switch.....	4-5
Turn Power ON.....	4-5
Check Indicator Lights.....	4-5
Adjust Gas Pressure and Current Setting.....	4-6
Hand Torch Operation.....	4-7
Safety Trigger Operation.....	4-7
Attach the Work Clamp.....	4-8
Starting a Cut from the Edge of the Workpiece.....	4-8
Hand Torch Cutting Technique.....	4-9
Piercing.....	4-10
Gouging.....	4-11
Cut Charts.....	4-12
Section 5 Maintenance and Parts	
Routine Maintenance.....	5-2
Inspect Consumables.....	5-3

Controls and Indicators5-4
Basic Troubleshooting5-5
System Circuit Diagram5-8
Technical Questions5-9
Parts5-10
 Torch Consumable Configurations5-10
 Torch Parts5-11
 Power Supply Parts5-11
 Accessories5-12

TABLE OF CONTENTS

Section 1

SAFETY

In this section:

Recognize Safety Information	1-2
Follow Safety Instructions	1-2
Cutting Can Cause Fire or Explosion	1-2
Electric Shock Can Kill	1-3
Cutting Can Produce Toxic Fumes	1-3
A Plasma Arc Can Cause Injury and Burns	1-4
Arc Rays Can Burn Eyes and Skin	1-4
Grounding Safety	1-4
Compressed Gas Equipment Safety	1-5
Gas Cylinders Can Explode If Damaged	1-5
Noise Can Damage Hearing	1-5
Pacemaker and Hearing Aid Operation	1-5
A Plasma Arc Can Damage Frozen Pipes	1-5
Additional Safety Information	1-5
Warning Label	1-6



RECOGNIZE SAFETY INFORMATION

The symbols shown in this section are used to identify potential hazards. When you see a safety symbol in this manual or on your machine, understand the potential for personal injury, and follow the related instructions to avoid the hazard.



FOLLOW SAFETY INSTRUCTIONS

Read carefully all safety messages in this manual and safety labels on your machine.

- Keep the safety labels on your machine in good condition. Replace missing or damaged labels immediately.
- Learn how to operate the machine and how to use the controls properly. Do not let anyone operate it without instruction.

- Keep your machine in proper working condition. Unauthorized modifications to the machine may affect safety and machine service life.

DANGER WARNING CAUTION

A signal word DANGER or WARNING is used with a safety symbol. DANGER identifies the most serious hazards.

- DANGER and WARNING safety labels are located on your machine near specific hazards.
- WARNING safety messages precede related instructions in this manual that may result in injury or death if not followed correctly.
- CAUTION safety messages precede related instructions in this manual that may result in damage to equipment if not followed correctly.



CUTTING CAN CAUSE FIRE OR EXPLOSION

Fire Prevention

- Be sure the area is safe before doing any cutting. Keep a fire extinguisher nearby.
- Remove all flammables within 35 feet (10 m) of the cutting area.
- Quench hot metal or allow it to cool before handling or before letting it touch combustible materials.
- Never cut containers with potentially flammable materials inside – they must be emptied and properly cleaned first.
- Ventilate potentially flammable atmospheres before cutting.
- When cutting with oxygen as the plasma gas, an exhaust ventilation system is required.

Explosion Prevention

- Do not use the plasma system if explosive dust or vapors may be present.
- Do not cut pressurized cylinders, pipes, or any closed container.
- Do not cut containers that have held combustible materials.



WARNING

Explosion Hazard
Argon-Hydrogen and Methane

Hydrogen and methane are flammable gases that present an explosion hazard. Keep flames away from cylinders and hoses that contain methane or hydrogen mixtures. Keep flames and sparks away from the torch when using methane or argon-hydrogen plasma.



WARNING

Hydrogen Detonation with
Aluminum Cutting

- When cutting aluminum underwater, or with the water touching the underside of the aluminum, free hydrogen gas may collect under the workpiece and detonate during plasma cutting operations.
- Install an aeration manifold on the floor of the water table to eliminate the possibility of hydrogen detonation. Refer to the Appendix section of this manual for aeration manifold details.



ELECTRIC SHOCK CAN KILL

Touching live electrical parts can cause a fatal shock or severe burn.

- Operating the plasma system completes an electrical circuit between the torch and the workpiece. The workpiece and anything touching the workpiece are part of the electrical circuit.
- Never touch the torch body, workpiece or the water in a water table when the plasma system is operating.

Electric Shock Prevention

All Hypertherm plasma systems use high voltage in the cutting process (200 to 400 VDC are common). Take the following precautions when operating this system:

- Wear insulated gloves and boots, and keep your body and clothing dry.
- Do not stand, sit or lie on – or touch – any wet surface when using the plasma system.
- Insulate yourself from work and ground using dry insulating mats or covers big enough to prevent any physical contact with the work or ground. If you must work in or near a damp area, use extreme caution.
- Provide a disconnect switch close to the power supply with properly sized fuses. This switch allows the operator to turn off the power supply quickly in an emergency situation.
- When using a water table, be sure that it is correctly connected to earth ground.

- Install and ground this equipment according to the instruction manual and in accordance with national and local codes.
- Inspect the input power cord frequently for damage or cracking of the cover. Replace a damaged power cord immediately. **Bare wiring can kill.**
- Inspect and replace any worn or damaged torch leads.
- Do not pick up the workpiece, including the waste cutoff, while you cut. Leave the workpiece in place or on the workbench with the work cable attached during the cutting process.
- Before checking, cleaning or changing torch parts, disconnect the main power or unplug the power supply.
- Never bypass or shortcut the safety interlocks.
- Before removing any power supply or system enclosure cover, disconnect electrical input power. Wait 5 minutes after disconnecting the main power to allow capacitors to discharge.
- Never operate the plasma system unless the power supply covers are in place. Exposed power supply connections present a severe electrical hazard.
- When making input connections, attach proper grounding conductor first.
- Each Hypertherm plasma system is designed to be used only with specific Hypertherm torches. Do not substitute other torches which could overheat and present a safety hazard.



CUTTING CAN PRODUCE TOXIC FUMES

Cutting can produce toxic fumes and gases that deplete oxygen and cause injury or death.

- Keep the cutting area well ventilated or use an approved air-supplied respirator.
- Do not cut in locations near degreasing, cleaning or spraying operations. The vapors from certain chlorinated solvents decompose to form phosgene gas when exposed to ultraviolet radiation.
- Do not cut metal coated or containing toxic materials, such as zinc (galvanized), lead, cadmium or beryllium, unless the area is well ventilated and the operator wears an air-supplied respirator. The coatings and any metals containing these elements can produce toxic fumes when cut.
- Never cut containers with potentially toxic materials inside – they must be emptied and properly cleaned first.
- This product, when used for welding or cutting, produces fumes or gases which contain chemicals known to the State of California to cause birth defects and, in some cases, cancer.



A PLASMA ARC CAN CAUSE INJURY AND BURNS

Instant-On Torches

Plasma arc comes on immediately when the torch switch is activated.

The plasma arc will cut quickly through gloves and skin.

- Keep away from the torch tip.
- Do not hold metal near the cutting path.
- Never point the torch toward yourself or others.



ARC RAYS CAN BURN EYES AND SKIN

Eye Protection Plasma arc rays produce intense visible and invisible (ultraviolet and infrared) rays that can burn eyes and skin.

- Use eye protection in accordance with applicable national or local codes.
- Wear eye protection (safety glasses or goggles with side shields, and a welding helmet) with appropriate lens shading to protect your eyes from the arc's ultraviolet and infrared rays.

Skin Protection Wear protective clothing to protect against burns caused by ultraviolet light, sparks and hot metal.

- Gauntlet gloves, safety shoes and hat.
- Flame-retardant clothing to cover all exposed areas.
- Cuffless trousers to prevent entry of sparks and slag.
- Remove any combustibles, such as a butane lighter or matches, from your pockets before cutting.

Arc Current
Up to 100 A
100-200 A
200-400 A
Over 400 A



Lens Shade	
AWS (USA)	ISO 4850
No. 8	No. 11
No. 10	No. 11-12
No. 12	No. 13
No. 14	No. 14

Cutting Area Prepare the cutting area to reduce reflection and transmission of ultraviolet light:

- Paint walls and other surfaces with dark colors to reduce reflection.
- Use protective screens or barriers to protect others from flash and glare.
- Warn others not to watch the arc. Use placards or signs.



GROUNDING SAFETY

Work Cable Attach the work cable securely to the workpiece or the work table with good metal-to-metal contact. Do not connect it to the piece that will fall away when the cut is complete.

Work Table Connect the work table to an earth ground, in accordance with appropriate national or local electrical codes.

Input Power

- Be sure to connect the power cord ground wire to the ground in the disconnect box.
- If installation of the plasma system involves connecting the power cord to the power supply, be sure to connect the power cord ground wire properly.
- Place the power cord's ground wire on the stud first, then place any other ground wires on top of the power cord ground. Fasten the retaining nut tightly.
- Tighten all electrical connections to avoid excessive heating.

COMPRESSED GAS EQUIPMENT SAFETY

- Never lubricate cylinder valves or regulators with oil or grease.
- Use only correct gas cylinders, regulators, hoses and fittings designed for the specific application.
- Maintain all compressed gas equipment and associated parts in good condition.
- Label and color-code all gas hoses to identify the type of gas in each hose. Consult applicable national or local codes.

**GAS CYLINDERS CAN EXPLODE IF DAMAGED**

Gas cylinders contain gas under high pressure. If damaged, a cylinder can explode.

- Handle and use compressed gas cylinders in accordance with applicable national or local codes.
- Never use a cylinder that is not upright and secured in place.
- Keep the protective cap in place over valve except when the cylinder is in use or connected for use.
- Never allow electrical contact between the plasma arc and a cylinder.
- Never expose cylinders to excessive heat, sparks, slag or open flame.
- Never use a hammer, wrench or other tool to open a stuck cylinder valve.

**NOISE CAN DAMAGE HEARING**

Prolonged exposure to noise from cutting or gouging can damage hearing.

- Use approved ear protection when using plasma system.
- Warn others nearby about the noise hazard.

**PACEMAKER AND HEARING AID OPERATION**

Pacemaker and hearing aid operation can be affected by magnetic fields from high currents. Pacemaker and hearing aid wearers should consult a doctor before going near any plasma arc cutting and gouging operations.

To reduce magnetic field hazards:

- Keep both the work cable and the torch lead to one side, away from your body.
- Route the torch leads as close as possible to the work cable.
- Do not wrap or drape the torch lead or work cable around your body.
- Keep as far away from the power supply as possible.

**A PLASMA ARC CAN DAMAGE FROZEN PIPES**

Frozen pipes may be damaged or can burst if you attempt to thaw them with a plasma torch.

ADDITIONAL SAFETY INFORMATION

1. ANSI Standard Z49.1, *Safety in Welding and Cutting*, American Welding Society, 550 LeJeune Road P.O. Box 351020, Miami, FL 33135
2. ANSI Standard Z49.2, *Fire Prevention in the Use of Cutting and Welding Processes*, American National Standards Institute 1430 Broadway, New York, NY 10018
3. ANSI Standard Z87.1, *Safe Practices for Occupation and Educational Eye and Face Protection*, American National Standards Institute, 1430 Broadway, New York, NY 10018
4. AWS F4.1, *Recommended Safe Practices for the Preparation for Welding and Cutting of Containers and Piping That Have Held Hazardous Substances*, American Welding Society 550 LeJeune Road, P.O. Box 351040, Miami, FL 33135
5. AWS F5.2, *Recommended Safe Practices for Plasma Arc Cutting*, American Welding Society 550 LeJeune Road, P.O. Box 351040, Miami, FL 33135
6. CGA Pamphlet P-1, *Safe Handling of Compressed Gases in Cylinders*, Compressed Gas Association 1235 Jefferson Davis Highway, Arlington, VA 22202
7. CSA Standard W117.2, *Code for Safety in Welding and Cutting*, Canadian Standards Association Standard Sales 178 Rexdale Boulevard, Rexdale, Ontario M9W 1R3, Canada
8. NFPA Standard 51B, *Cutting and Welding Processes*, National Fire Protection Association 470 Atlantic Avenue, Boston, MA 02210
9. NFPA Standard 70-1978, *National Electrical Code*, National Fire Protection Association, 470 Atlantic Avenue, Boston, MA 02210
10. OSHA, *Safety and Health Standards*, 29FR 1910 U.S. Government Printing Office, Washington, D.C. 20402

WARNING LABEL

This warning label is affixed to some power supplies. It is important that the operator and maintenance technician understand the intent of these warning symbols as described. The numbered text corresponds to the numbered boxes on the label.



1. Cutting sparks can cause explosion or fire.
 - 1.1 Keep flammables away from cutting.
 - 1.2 Keep a fire extinguisher nearby, and have a watchperson ready to use it.
 - 1.3 Do not cut on any closed containers.
2. The plasma arc can cause injury and burns.
 - 2.1 Turn off power before disassembling torch.
 - 2.2 Do not hold the material near cutting path.
 - 2.3 Wear complete body protection.
3. Electric shock from torch or wiring can kill. Protect yourself from electric shock.
 - 3.1 Wear insulating gloves. Do not wear wet or damaged gloves.
 - 3.2 Insulate yourself from work and ground.
 - 3.3 Disconnect input plug or power before working on machine.
4. Breathing cutting fumes can be hazardous to your health.
 - 4.1 Keep your head out of the fumes.
 - 4.2 Use forced ventilation or local exhaust to remove the fumes.
 - 4.3 Use ventilating fan to remove the fumes.
5. Arc rays can burn eyes and injure skin.
 - 5.1 Wear hat and safety glasses. Use ear protection and button shirt collar. Use welding helmet with correct shade of filter. Wear complete body protection.
6. Become trained and read the instructions before working on the machine or cutting.
7. Do not remove or paint over (cover) warning labels.

Dans cette section :

Identifier les consignes de sécurité	1a-2
Suivre les instructions de sécurité.....	1a-2
Danger Avertissement Précaution.....	1a-2
Le coupage peut provoquer un incendie ou une explosion.....	1a-2
Prévention des incendies, Prévention des explosions	1a-2
Risque d'explosion argon-hydrogène et méthane	1a-2
Détonation de l'hydrogène lors du coupage de l'aluminium	1a-2
Les chocs électriques peuvent être fatals	1a-3
Prévention des chocs électriques	1a-3
Le coupage peut produire des vapeurs toxiques	1a-3
L'arc plasma peut provoquer des blessures ou des brûlures	1a-4
Torches à allumage instantané.....	1a-4
Les rayons de l'arc peuvent brûler les yeux et la peau	1a-4
Protection des yeux, Protection de la peau, Zone de coupage	1a-4
Mise à la masse et à la terre	1a-4
Câble de retour, Table de travail, Alimentation	1a-4
Sécurité des bouteilles de gaz comprimé	1a-5
Les bouteilles de gaz comprimé peuvent exploser en cas de dommages.....	1a-5
Le bruit peut provoquer des problèmes auditifs	1a-5
Pacemakers et prothèses auditives	1a-5
Un arc plasma peut endommager les tuyaux gelés	1a-5
Étiquette de sécurité	1a-6



IDENTIFIER LES CONSIGNES DE SÉCURITÉ

Les symboles indiqués dans cette section sont utilisés pour identifier les risques éventuels. Si vous trouvez un symbole de sécurité, que ce soit dans ce manuel ou sur l'équipement, soyez conscient des risques de blessures et suivez les instructions correspondantes afin d'éviter ces risques.



SUIVRE LES INSTRUCTIONS DE SÉCURITÉ

Lire attentivement toutes les consignes de sécurité dans le présent manuel et sur les étiquettes de sécurité se trouvant sur la machine.

- Les étiquettes de sécurité doivent rester lisibles. Remplacer immédiatement les étiquettes manquantes ou abîmées.
- Apprendre à faire fonctionner la machine et à utiliser correctement les commandes. Ne laisser personne utiliser la machine sans connaître son fonctionnement.

- Garder la machine en bon état. Des modifications non autorisées sur la machine peuvent engendrer des problèmes de sécurité et raccourcir la durée d'utilisation de l'équipement.

DANGER AVERTISSEMENT PRÉCAUTION

Les signaux DANGER ou AVERTISSEMENT sont utilisés avec un symbole de sécurité, DANGER correspondant aux risques les plus sérieux.

- Les étiquettes de sécurité DANGER et AVERTISSEMENT sont situées sur la machine pour signaler certains dangers spécifiques.
- Les messages d'AVERTISSEMENT précèdent les instructions d'utilisation expliquées dans ce manuel et signalent les risques de blessures ou de mort au cas où ces instructions ne seraient pas suivies correctement.
- Les messages de PRÉCAUTION précèdent les instructions d'utilisation contenues dans ce manuel et signalent que le matériel risque d'être endommagé si les instructions ne sont pas suivies correctement.



LE COUPAGE PEUT PROVOQUER UN INCENDIE OU UNE EXPLOSION

Prévention des incendies

- Avant de commencer, s'assurer que la zone de coupage ne présente aucun danger. Conserver un extincteur à proximité.
- Éloigner toute matière inflammable à une distance d'au moins 10 m du poste de coupage.
- Tremper le métal chaud ou le laisser refroidir avant de le manipuler ou avant de le mettre en contact avec des matériaux combustibles.
- Ne jamais couper des récipients pouvant contenir des matières inflammables avant de les avoir vidés et nettoyés correctement.
- Aérer toute atmosphère potentiellement inflammable avant d'utiliser un système plasma.
- Lors de l'utilisation d'oxygène comme gaz plasma, un système de ventilation par aspiration est nécessaire.

Prévention des explosions

- Ne pas couper en présence de poussière ou de vapeurs.
- Ne pas couper de bouteilles, de tuyaux ou autres récipients fermés et pressurisés.
- Ne pas couper de récipients contenant des matières combustibles.



AVERTISSEMENT

Risque d'explosion argon-hydrogène et méthane

L'hydrogène et le méthane sont des gaz inflammables et potentiellement explosifs. Conserver à l'écart de toute flamme les bouteilles et tuyaux contenant des mélanges à base d'hydrogène ou de méthane. Maintenir toute flamme et étincelle à l'écart de la torche lors de l'utilisation d'un plasma d'argon-hydrogène ou de méthane.



AVERTISSEMENT

Détonation de l'hydrogène lors du coupage de l'aluminium

- Lors du coupage de l'aluminium sous l'eau, ou si l'eau touche la partie inférieure de la pièce d'aluminium, de l'hydrogène libre peut s'accumuler sous la pièce à couper et détonner lors du coupage plasma.
- Installer un collecteur d'aération au fond de la table à eau afin d'éliminer les risques de détonation de l'hydrogène. Se référer à l'annexe du manuel pour plus de renseignements sur les collecteurs d'aération.



LES CHOCS ÉLECTRIQUES PEUVENT ÊTRE FATALS

Toucher une pièce électrique sous tension peut provoquer un choc électrique fatal ou des brûlures graves.

- La mise en fonctionnement du système plasma ferme un circuit électrique entre la torche et la pièce à couper. La pièce à couper et tout autre élément en contact avec cette pièce font partie du circuit électrique.
- Ne jamais toucher le corps de la torche, la pièce à couper ou l'eau de la table à eau pendant le fonctionnement du système plasma.

Prévention des chocs électriques

Tous les systèmes plasma Hypertherm utilisent des hautes tensions pour le coupage (souvent de 200 à 400 V). On doit prendre les précautions suivantes quand on utilise le système plasma :

- Porter des bottes et des gants isolants et garder le corps et les vêtements au sec.
- Ne pas se tenir, s'asseoir ou se coucher sur une surface mouillée, ni la toucher quand on utilise le système plasma.
- S'isoler de la surface de travail et du sol en utilisant des tapis isolants secs ou des couvertures assez grandes pour éviter tout contact physique avec le travail ou le sol. S'il s'avère nécessaire de travailler dans ou près d'un endroit humide, procéder avec une extrême prudence.
- Installer un sectionneur avec fusibles appropriés, à proximité de la source de courant. Ce dispositif permet à l'opérateur d'arrêter rapidement la source de courant en cas d'urgence.
- En cas d'utilisation d'une table à eau, s'assurer que cette dernière est correctement mise à la terre.

- Installer et mettre à la terre l'équipement selon les instructions du présent manuel et conformément aux codes électriques locaux et nationaux.
- Inspecter fréquemment le cordon d'alimentation primaire pour s'assurer qu'il n'est ni endommagé, ni fendu. Remplacer immédiatement un cordon endommagé.

Un câble dénudé peut tuer.

- Inspecter et remplacer les câbles de la torche qui sont usés ou endommagés.
- Ne pas saisir la pièce à couper ni les chutes lors du coupage. Laisser la pièce à couper en place ou sur la table de travail, le câble de retour connecté lors du coupage.
- Avant de vérifier, de nettoyer ou de remplacer les pièces de la torche, couper l'alimentation ou débrancher la prise de courant.
- Ne jamais contourner ou court-circuiter les verrouillages de sécurité.
- Avant d'enlever le capot du système ou de la source de courant, couper l'alimentation électrique. Attendre ensuite 5 minutes pour que les condensateurs se déchargent.
- Ne jamais faire fonctionner le système plasma sans que les capots de la source de courant ne soient en place. Les raccords exposés de la source de courant sont extrêmement dangereux.
- Lors de l'installation des connexions, attacher tout d'abord la prise de terre appropriée.
- Chaque système plasma Hypertherm est conçu pour être utilisé uniquement avec des torches Hypertherm spécifiques. Ne pas utiliser des torches inappropriées qui pourraient surchauffer et présenter des risques pour la sécurité.



LE COUPAGE PEUT PRODUIRE DES VAPEURS TOXIQUES

Le coupage peut produire des vapeurs et des gaz toxiques qui réduisent le niveau d'oxygène dans l'air et peuvent provoquer des blessures, voire la mort.

- Conserver le poste de coupage bien aéré ou utiliser un masque respiratoire homologué.
- Ne pas procéder au coupage près d'endroits où s'effectuent le dégraissage, le nettoyage ou la vaporisation. Certains solvants chlorés se décomposent sous l'effet des rayons ultraviolets et forment du phosgène.
- Ne pas couper des métaux peints ou contenant des matières toxiques comme le zinc (galvanisé), le plomb, le cadmium ou le béryllium, à moins que la zone de travail

soit très bien ventilée et que l'opérateur porte un masque respiratoire. Les revêtements et métaux contenant ces matières peuvent produire des vapeurs toxiques lors du coupage.

- Ne jamais couper de récipients pouvant contenir des matières inflammables avant de les avoir vidés et nettoyés correctement.
- Quand on utilise ce produit pour le soudage ou le coupage, il dégage des fumées et des gaz qui contiennent des produits chimiques qui, selon l'État de Californie, provoquent des anomalies congénitales et, dans certains cas, le cancer.



L'ARC PLASMA PEUT PROVOQUER DES BLESSURES OU DES BRÛLURES

Torches à allumage instantané

L'arc plasma s'allume immédiatement après que la torche soit mise en marche.

L'arc plasma coupe facilement les gants et la peau.

- Rester éloigné de l'extrémité de la torche.
- Ne pas tenir de métal près de la trajectoire de coupe.
- Ne jamais pointer la torche vers soi ou d'autres personnes.



LES RAYONS DE L'ARC PEUVENT BRÛLER LES YEUX ET LA PEAU

Protection des yeux Les rayons de l'arc plasma produisent de puissants rayons visibles ou invisibles (ultraviolets et infrarouges) qui peuvent brûler les yeux et la peau.

- Utiliser des lunettes de sécurité conformément aux codes locaux ou nationaux en vigueur.
- Porter des lunettes de protection (lunettes ou masque muni d'écrans latéraux et encore masque de soudure) avec des verres teintés appropriés pour protéger les yeux des rayons ultraviolets et infrarouges de l'arc.

Protection de la peau Porter des vêtements de sécurité pour se protéger contre les brûlures que peuvent causer les rayons ultraviolets, les étincelles et le métal brûlant :

- Gants à crispin, chaussures et casque de sécurité.
- Vêtements ignifuges couvrant toutes les parties exposées du corps.
- Pantalon sans revers pour éviter que des étincelles ou des scories puissent s'y loger.
- Avant le coupage, retirer de ses poches tout objet combustible comme les briquets au butane ou les allumettes.

Courant de l'arc

Jusqu'à 100 A
100-200 A
200-400 A
Plus de 400 A



Puissance des verres teintés

AWS (É.-U.)

N° 8

N° 10

N° 12

N° 14

ISO 4850

N° 11

N° 11-12

N° 13

N° 14



Zone de coupage Préparer la zone de coupage afin de réduire la réverbération et la transmission de la lumière ultraviolette :

- Peindre les murs et autres surfaces de couleur sombre pour réduire la réflexion de la lumière.
- Utiliser des écrans et autres dispositifs de protection afin de protéger les autres personnes de la lumière et de la réverbération.
- Prévenir les autres personnes de ne pas regarder l'arc. Utiliser des affiches ou des panneaux.



MISE À LA MASSE ET À LA TERRE

Câble de retour Bien fixer le câble de retour (ou de masse) à la pièce à couper ou à la table de travail de façon à assurer un bon contact métal-métal. Ne pas fixer le câble de retour à la partie de la pièce qui doit se détacher.

Table de travail Raccorder la table de travail à la terre, conformément aux codes de sécurité locaux ou nationaux appropriés.

Alimentation

- S'assurer que le fil de terre du cordon d'alimentation est connecté à la terre dans le coffret du sectionneur.
- S'il est nécessaire de brancher le cordon d'alimentation à la source de courant lors de l'installation du système, s'assurer que le fil de terre est correctement branché.
- Placer tout d'abord le fil de terre du cordon d'alimentation sur le plot de mise à la terre puis placer les autres fils de terre par-dessus. Bien serrer l'écrou de retenue.
- S'assurer que toutes les connexions sont bien serrées pour éviter la surchauffe.

SÉCURITÉ DES BOUTEILLES DE GAZ COMPRIMÉ

- Ne jamais lubrifier les robinets des bouteilles ou les régulateurs avec de l'huile ou de la graisse.
- Utiliser uniquement les bouteilles, régulateurs, tuyaux et accessoires appropriés et conçus pour chaque application spécifique.
- Entretenir l'équipement et les pièces d'équipement à gaz comprimé afin de les garder en bon état.
- Étiqueter et coder avec des couleurs tous les tuyaux de gaz afin d'identifier le type de gaz contenu dans chaque tuyau. Se référer aux codes locaux ou nationaux en vigueur.



LES BOUTEILLES DE GAZ COMPRIMÉ PEUVENT EXPLOSER EN CAS DE DOMMAGES

Les bouteilles de gaz contiennent du gaz à haute pression. Si une bouteille est endommagée, elle peut exploser.

- Manipuler et utiliser les bouteilles de gaz comprimé conformément aux codes locaux ou nationaux.
- Ne jamais utiliser une bouteille qui n'est pas placée à la verticale et bien assujettie.
- Le capuchon de protection doit être placé sur le robinet sauf si la bouteille est en cours d'utilisation ou connectée pour utilisation.
- Éviter à tout prix le contact électrique entre l'arc plasma et une bouteille.
- Ne jamais exposer des bouteilles à une chaleur excessive, aux étincelles, aux scories ou aux flammes nues.
- Ne jamais utiliser des marteaux, des clés ou d'autres outils pour débloquer le robinet des bouteilles.



LE BRUIT PEUT PROVOQUER DES PROBLÈMES AUDITIFS

Une exposition prolongée au bruit du coupage ou du gougeage peut provoquer des problèmes auditifs.

- Utiliser un casque de protection homologué lors de l'utilisation du système plasma.
- Prévenir les personnes aux alentours des risques encourus en cas d'exposition au bruit.



PACEMAKERS ET PROTHÈSES AUDITIVES

Les champs magnétiques produits par les courants à haute tension peuvent affecter le fonctionnement des prothèses auditives et des pacemakers. Les personnes portant ce type d'appareil doivent consulter un médecin avant de s'approcher d'un lieu où s'effectue le coupage ou le gougeage plasma.

Pour réduire les risques associés aux champs magnétiques :

- Garder loin de soi et du même côté du corps le câble de retour et le faisceau de la torche.
- Faire passer le faisceau de la torche le plus près possible du câble de retour.
- Ne pas s'enrouler le faisceau de la torche ou le câble de retour autour du corps.
- Se tenir le plus loin possible de la source de courant.



UN ARC PLASMA PEUT ENDOMMAGER LES TUYAUX GELÉS

Les tuyaux gelés peuvent être endommagés ou éclater si l'on essaie de les dégeler avec une torche plasma.

Étiquette de sécurité

Cette étiquette est affichée sur la source de courant. Il est important que l'utilisateur et le technicien de maintenance comprennent la signification des symboles de sécurité. Les numéros de la liste correspondent aux numéros des images.



1. Les étincelles produites par le coupage peuvent provoquer une explosion ou un incendie.
 - 1.1 Pendant le coupage, éloigner toute matière inflammable.
 - 1.2 Conserver un extincteur à proximité et s'assurer qu'une personne soit prête à l'utiliser.
 - 1.3 Ne jamais couper de récipients fermés.
2. L'arc plasma peut provoquer des blessures et des brûlures.
 - 2.1 Couper l'alimentation avant de démonter la torche.
 - 2.2 Ne pas tenir la surface à couper près de la trajectoire de coupe.
 - 2.3 Porter des vêtements de protection couvrant tout le corps.
3. Un choc électrique causé par la torche ou les câbles peut être fatal. Se protéger contre les risques de chocs électriques.
 - 3.1 Porter des gants isolants. Ne pas porter de gants mouillés ou abîmés.
 - 3.2 S'isoler de la surface de travail et du sol.
 - 3.3 Débrancher la prise ou la source de courant avant de manipuler l'équipement.
4. L'inhalation des vapeurs produites par le coupage peut être dangereuse pour la santé.
 - 4.1 Garder le visage à l'écart des vapeurs.
 - 4.2 Utiliser un système de ventilation par aspiration ou d'échappement localisé pour dissiper les vapeurs.
 - 4.3 Utiliser un ventilateur pour dissiper les vapeurs.
5. Les rayons de l'arc peuvent brûler les yeux et provoquer des lésions de la peau.
 - 5.1 Porter un casque et des lunettes de sécurité. Se protéger les oreilles et porter une chemise dont le col peut être déboutonné. Porter un casque de soudure dont la protection filtrante est suffisante. Porter des vêtements protecteurs couvrant la totalité du corps.
6. Se former à la technique du coupage et lire les instructions avant de manipuler l'équipement ou de procéder au coupage.
7. Ne pas retirer ou peindre (recouvrir) les étiquettes de sécurité.

Section 2

SPECIFICATIONS

In this section:

Specifications – Power Supply	2-2
Power Supply – Dimensions and Weight.....	2-3
Specifications – T60 Torches	2-4
Torch Dimensions.....	2-5
Symbols and Markings.....	2-6

SPECIFICATIONS

Specifications – Power Supply

Rated Open Circuit Voltage (U_0)	300 VDC		
Output Characteristic* *Defined as a plot of output voltage versus output current	Drooping		
Rated Output Current (I_2)	20A – 60A		
Hypertherm Standard Rated Output Voltage (U_2)	140 VDC		
Duty Cycle (X^*) at 104°F (40°C) at rated conditions (U_1, I_1, U_2, I_2)	U_1 – Volts AC rms	X	
* $X = T_{on}/T_{base}$, T_{on} = time, minutes T_{base} = 10 minutes	200-208 VAC 1PH	40%	
	230-240 VAC 1PH	50%	
	480 VAC 1PH	50%	
	200-208 VAC 3PH	40%	
	230-240 VAC 3PH	50%	
	380-415 VAC 3PH	50%	
	480 VAC 3PH	50%	
	600 VAC 3PH	50%	
Operating temperature	14° to 104° F (-10° to 40° C)		
Rated AC phases (PH) and line frequency (Hz) Standard Model CE Model	PH	Hz	
	1-3 3	50-60 50-60	
Rated Input Voltage (U_1), rated Input Current (I_1) and I_{1eff} * at rated Output U_2 and I_2 – cutting only. * $I_{1eff} = (I_1)\sqrt{X}$ used to determine rating of power cord.	U_1 – Volts AC rms	I_1 -Amps rms	I_{1eff}
	200-208 VAC 1PH	50	32
	230-240 VAC 1PH	44	31
	480 VAC 1PH	22	15.5
	200-208 VAC 3PH	30	19
	230-240 VAC 3PH	26	18
	380-415 VAC 3PH	15	10.5
	480 VAC 3PH 600 VAC 3PH	12 11	8.5 8
Power Factor	U_1 – Volts AC rms	Harmonic Power Factor	Displacement Power Factor
	200-208 VAC 1PH	0.99	0.99
	230-240 VAC 1PH	0.99	0.99
	480 VAC 1PH	0.91	0.99
	200-208 VAC 3PH	0.94	0.99
	230-240 VAC 3PH	0.94	0.99
	380-415 VAC 3PH	0.94	0.99
	480 VAC 3PH 600 VAC 3PH	0.94 0.80	0.99 0.99
R_{scc} – Short Circuit Ratio—CE Model only	U_1 – Volts AC rms, 3PH	R_{scc}	
	400 VAC	153	
	230 VAC	97	
	<i>This equipment conforms to IEC 61000-3-12, provided that $R_{scc\ min} = 153$ at 400VAC 3PH and 97 at 230 VAC 3PH.</i>		
IP code—Degree of protection provided by enclosure	IP23CS* IP – “International Protection” 2 – No ingress foreign objects ≥ 12.5 mm (0.5 in) 3 – No harmful ingress spraying water C – AC line circuits protected against ingress of tool ≥ 2.5 mm dia. x 100 mm long (0.1 inch x 4.0 inch) S – fan stationary during water test *WARNING: DO NOT OPERATE IN RAIN		
Toppling, Tilting (with or without wheel kit)	Up to 15° incline.		
Gas Type	Air Nitrogen		
Gas Quality	Clean, moisture-free, oil-free		
Gas Inlet Pressure and Flow	See Section 3, Setup		

Power Supply – Dimensions and Weight

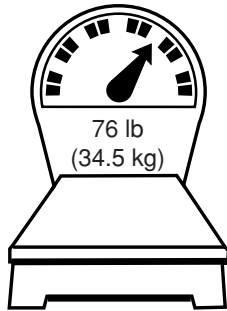

Weight of power supply without torch

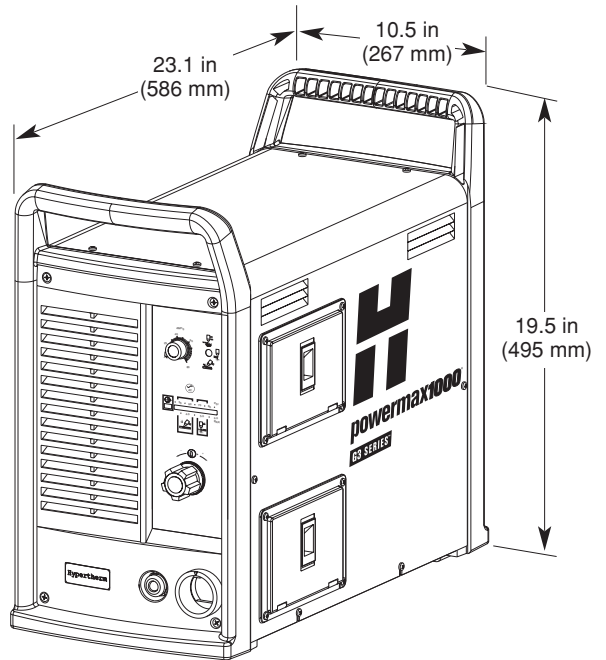

SPECIFICATIONS

Specifications – T60 Torches

Cutting Capacity At 60 Amps	
Recommended capacity	3/4 inch (19 mm)
Maximum capacity	1 inch (25 mm)
Severance capacity	1-1/4 inch (32 mm)
Gouging Capability (metal removal rate on mild steel)	10.0 pounds (4.5 kg) / hour
Weight	
T60	6.9 pounds (3.1 kg) with 25 ft (7.5 m) lead 13.6 pounds (6.2 kg) with 50 ft (15 m) lead
T60M	4.5 pounds (2.0 kg) with 15 ft (4.5 m) lead 8.3 pounds (3.8 kg) with 25 ft (7.5 m) lead 9.9 pounds (4.5 kg) with 35 ft (10.7 m) lead 15.0 pounds (6.8 kg) with 50 ft (15 m) lead

Torch Dimensions

T60 Hand Torch Dimensions

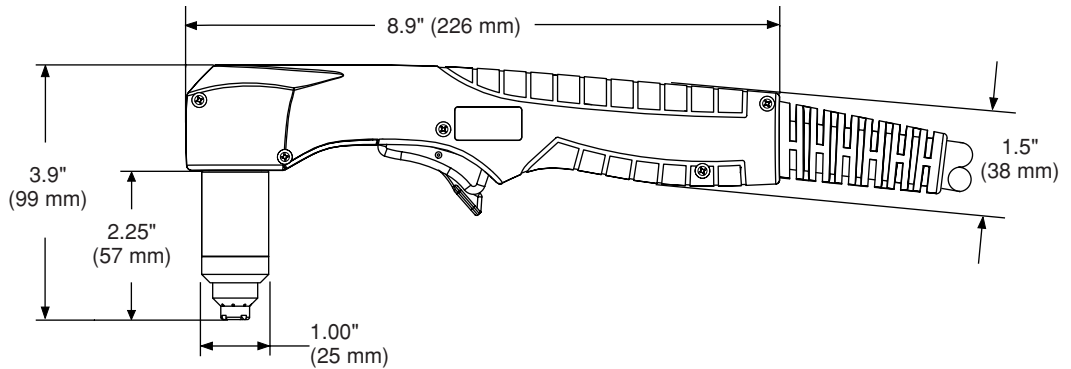

T60M/T80M Machine Torch Dimensions

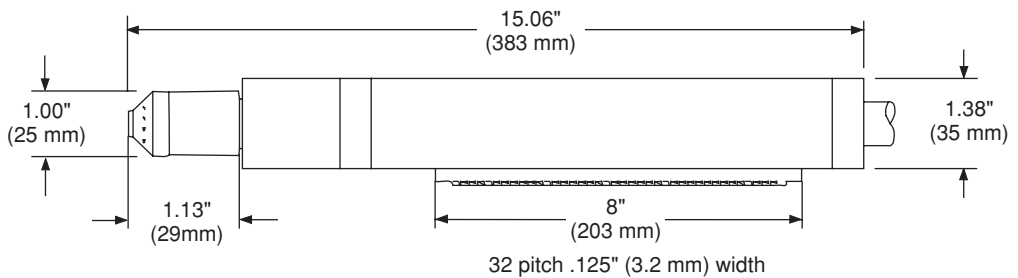











Symbols and Markings

S MARK

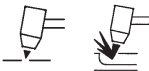
The **S** mark indicates that the power supply and torch are suitable for use in environments with increased hazard of electrical shock. The hand torches must have shielded consumable parts to maintain **S** mark compliance.

IEC Symbols Used

The following symbols may appear on the power supply data plate, control labels and switches.

	Direct Current (DC)		An inverter-based power source
	Alternating current (AC)		Plasma torch in the TEST position (cooling and cutting gas exiting nozzle)
	Plasma torch cutting and gouging		Power is on
	AC input power connection		Power is off
	The terminal for the external protective (earth) conductor		Volt/amp curve, "drooping" characteristic

Section 3

SETUP

In this section:

Upon Receipt	3-2
Claims	3-2
Contents of Box.....	3-2
Locating Power Supply	3-2
Lifting Power Supply	3-3
Power Connection.....	3-4
Three Phase Power Cord – Plug Installation	3-4
Single Phase Power Cord	3-5
Power Cord Installation	3-5
Plug Installation	3-5
Grounding	3-6
Extension Cords	3-6
Torch Installation	3-7
Plasma Gas Supply	3-9
Additional Gas Filtration	3-9
Gas Supply Installation	3-10
T60M Torch Alignment.....	3-10
ON/OFF Pendant Connection.....	3-11
Machine Interface Connection	3-11
Arc Voltage	3-12
Changing XFER (start machine motion) from dry contact closure to voltage signal.....	3-14

Upon Receipt

1. Check that all items on your order have been received. Contact your distributor/OEM if any items are missing or damaged.
2. If there is evidence of damage, refer to *Claims*, below. All communications regarding this equipment must include the model number and serial number located on the back of the power supply.
3. Read the *Safety* section of this manual before setting up and operating this Hypertherm system.

Claims

Claims for damage during shipment: If your unit was damaged during shipment, you must file a claim with the carrier. Hypertherm will furnish you with a copy of the bill of lading upon request. If you need additional assistance, call the nearest Hypertherm office listed in the front of this manual.

Claims for defective or missing merchandise: If any component is missing or defective, contact your Hypertherm distributor/OEM. If you need additional assistance, call the nearest Hypertherm office listed in the front of this manual.

Contents of Box

Verify items against the illustration shown (for hand system configurations).

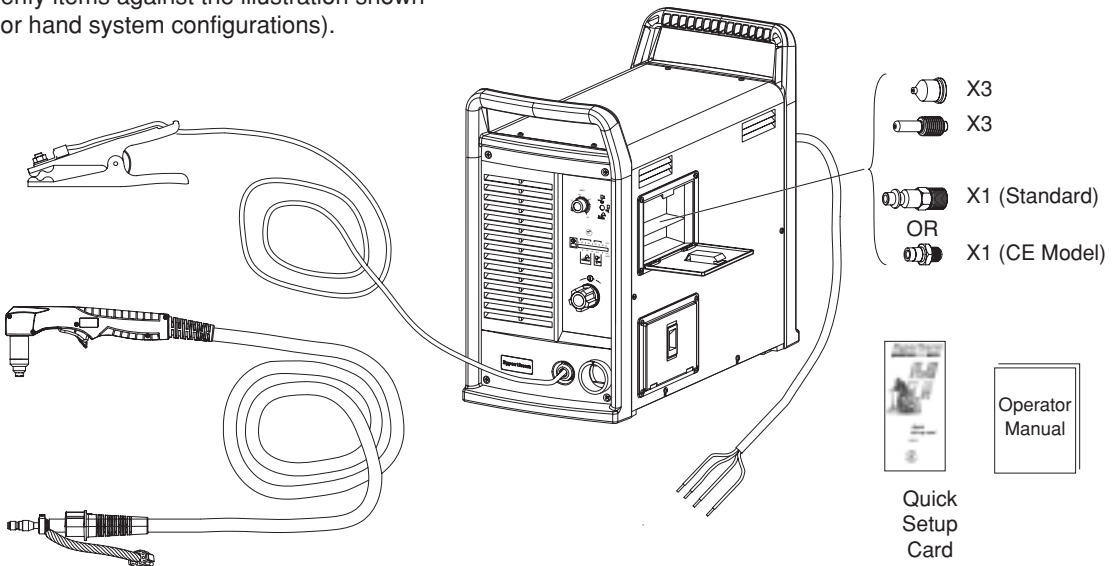

Locating Power Supply

Locate the Powermax1000 power supply with at least 10 inches (0.25 m) of open space at the front and back and fan side of the power supply for proper ventilation.

Lifting Power Supply

		WARNING
<ul style="list-style-type: none"> • The system weighs up to 83 lb / 38 kg. • Always lift the power supply by TWO handles • Do not lift the power supply by ONE handle. • The handle can break, resulting in injury and damage. 		

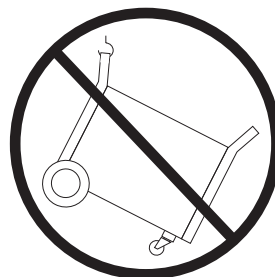
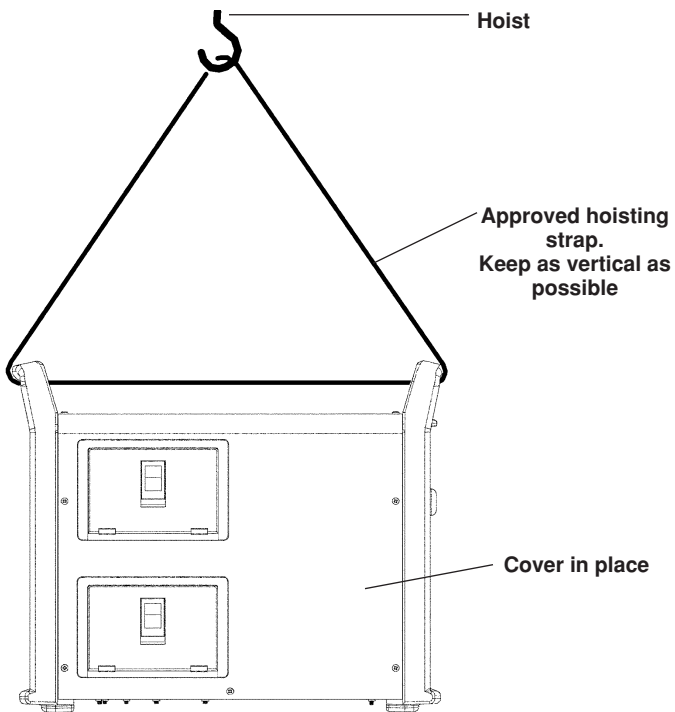

Power Connection

The Powermax1000 is a universal power supply that can configure itself to operate with AC voltages from 200 to 600 (230-400 3PH for CE model). Use a line disconnect switch for each power supply so that the operator can turn off the power supply quickly in an emergency. Locate the switch so it is easily accessible to the operator. The interrupt level of the switch must be equal to or exceed the continuous rating of the fuses. Use slow-blow fuses rated per local and national electrical codes.

Standard Model	Single Phase			Three Phase				
	Input Voltage	200-208	230-240	480	200-208	230-240	400	480
Input Current at 8.4kw Output	50	44	22	30	26	15	12	11
Input Current during Arc Stretch	75	75	38	45	45	26	20	19

CE Model	Three Phase	
Input Voltage	230	400
Input Current at 8.4kw Output	26	15
Input Current during Arc Stretch	45	26

Three-Phase Power Cord – Plug Installation

The Powermax1000 power supplies are shipped with an 8 AWG 4-wire power cord on standard models. A 4 mm², 4-wire HAR power cord is provided on CE models. To operate the Powermax1000, use a plug that meets national or local electrical codes. The plug must be connected to the power cord by a licensed electrician.

Single Phase Power Cord (not for CE model)

CAUTION: When using the standard model power supply (CE model is 3PH only) with a single-phase power source, replace the supplied power cord with a 8 AWG (10mm²) 3-wire power cord. The power cord must be connected by a licensed electrician.

Power Cord Installation

Strip and prepare the power cord wires as shown below:

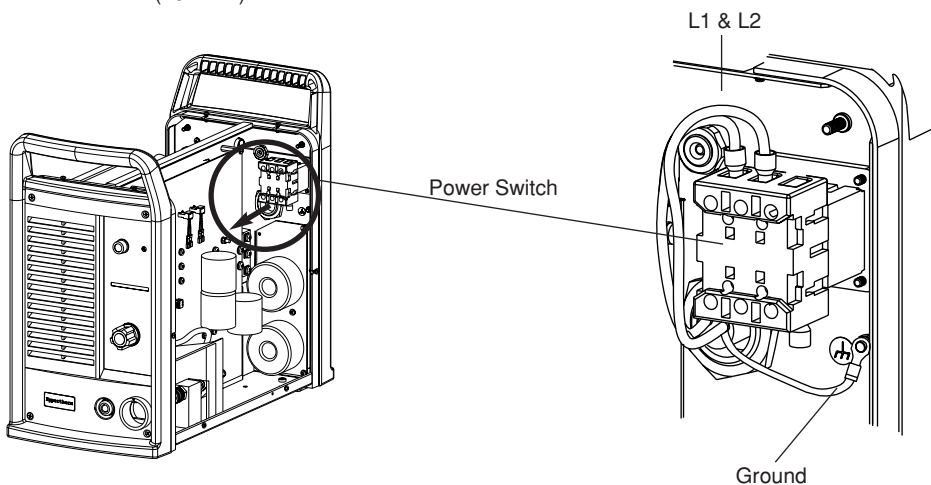
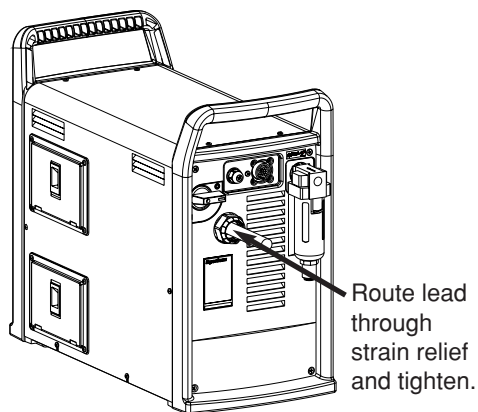
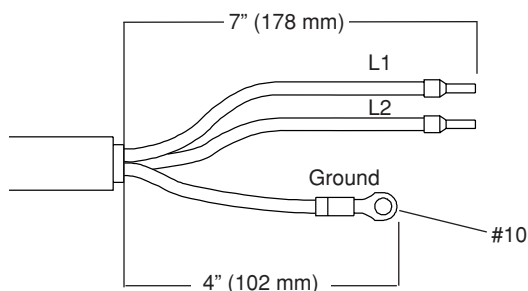

Plug Installation

The plug must be connected to the power cord by a licensed electrician.

Grounding

To ensure personal safety and proper operation, and to reduce electromagnetic interference (EMI), the Powermax1000 must be properly grounded through the power cord according to national or local electrical codes. Three-phase service must be of the 4-wire type with a green or green/yellow wire for protective earth ground and must comply with national or local electrical requirements. Single-phase service must be of the 3-wire type with a green or green/yellow wire for protective earth ground and must comply with national or local electrical requirements. Refer to *Grounding*, in the Safety section.

Extension Cords

Use a cord that is certified by national or local codes. The cord should be installed by a licensed electrician. Refer to the length requirements listed below.

		Recommended Extension Cord Gauge Size AWG (mm ²)									
		< 10 ft < 3 m		10-25 ft 3 – 7.5 m		25-50 ft 7.5 – 15 m		50-100 ft 15 – 30 m		100-150 ft 30 – 45 m	
Standard Model											
Input-Voltage	Phase	AWG	mm²	AWG	mm²	AWG	mm²	AWG	mm²	AWG	mm²
200-208 VAC	1	8	(10)	8	(10)	8	(10)	6	(16)	4	(25)
230 VAC	1	8	(10)	8	(10)	8	(10)	6	(16)	4	(25)
480 VAC	1	12	(4)	12	(4)	12	(4)	10	(6)	10	(6)
200-208 VAC	3	10	(6)	10	(6)	10	(6)	8	(10)	8	(10)
230 VAC	3	10	(6)	10	(6)	10	(6)	8	(10)	8	(10)
400 VAC	3	12	(4)	12	(4)	12	(4)	12	(4)	10	(6)
480 VAC	3	12	(4)	12	(4)	12	(4)	12	(4)	10	(6)
600 VAC	3	12	(4)	12	(4)	12	(4)	12	(4)	12	(4)
CE Model	Phase	mm²		mm²		mm²		mm²		mm²	
230 VAC	3	(4)		(4)		(6)		(6)		(10)	
400 VAC	3	(4)		(4)		(4)		(6)		(6)	

Torch Installation

- 1 Turn OFF power.

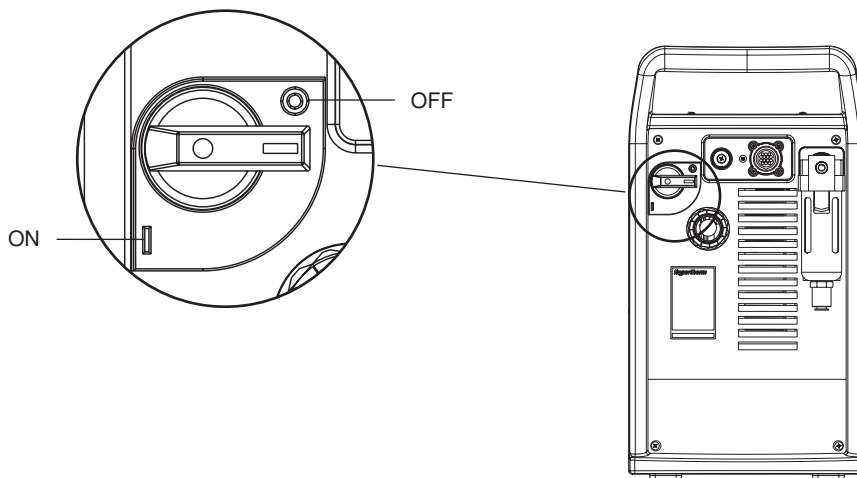

- 2 Remove power cord from power receptacle.

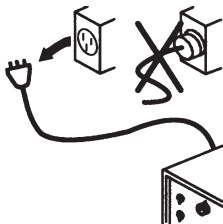

- 3 Open ETR door and route lead through the end cap.

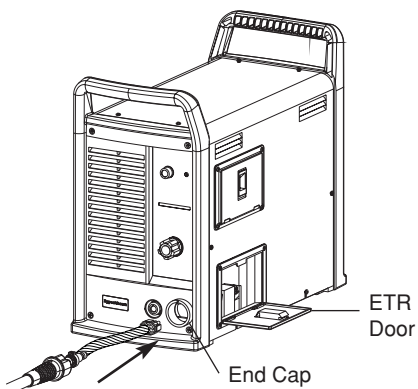

- 4 Align marks on strain relief.

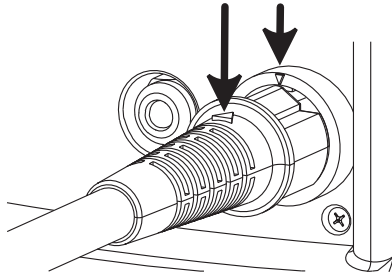

- 5 Pull back Quick Release collar and insert the lead's gas fitting.

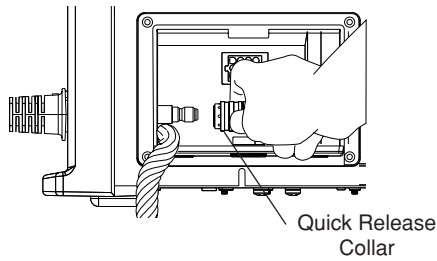

- 6 Slide Quick Release collar forward to lock in the gas fitting. Make sure that the gas fitting is secure.

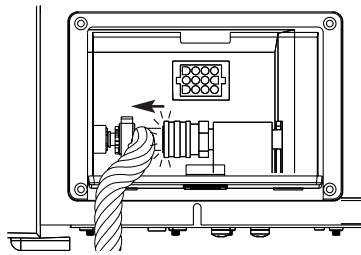

- 7 Make sure that the red dot on the connector is on top, then plug in the electrical connector. Close ETR door.

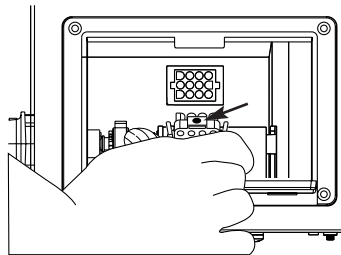

Plasma Gas Supply

The gas supply for the Powermax1000 can be shop compressed air or cylinder compressed air. A high-pressure regulator must be used on either type of supply and must be capable of delivering gas to the filter on the power supply at **400 scfh/6.7 scfm (189 l/min)**, minimum flow rate, at a minimum pressure of **90 psig (6.1 bar)**. If gas supply quality is poor, cut speeds decrease, cut quality deteriorates, cutting thickness capability decreases, and parts life shortens.



WARNING



Do not allow the air inlet pressure to the filter on the power supply to exceed **120 psi (8.3 bar)**.
The filter bowl may explode if this pressure is exceeded.

Additional Gas Filtration

Use Hypertherm filter kit, part #128647, when site conditions introduce moisture, oil or other particulates into the air line. A 3-stage coalescing filtration system, as shown, can also be used.

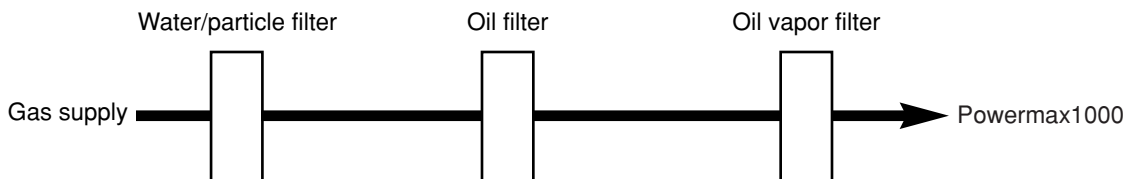

Gas Supply Installation

Connect the air hose as follows:

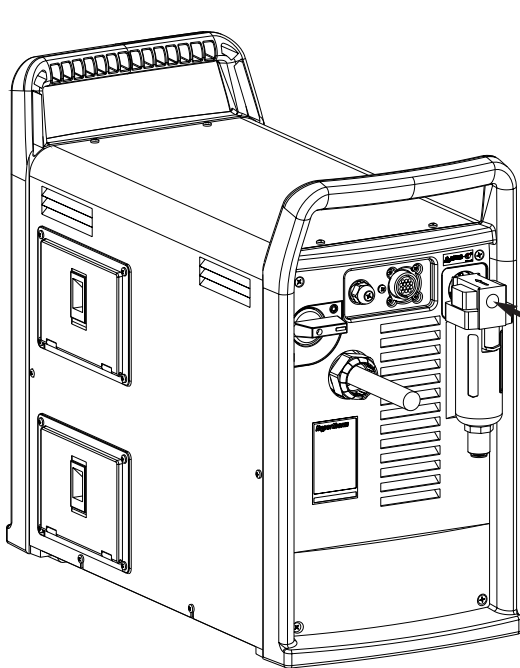

1. Air fitting

- For standard model: Install 1/4 NPT gas fitting on to air filter inlet. CE model provides G1/4 adapter, in CE kit. Use liquid pipe sealant on threads.

CAUTION: Never use Teflon tape when installing the nipple or adapters. Bits of tape can break off and enter the air line and harm the pressure regulator, pressure switch and valve.

- Nipple/Adapter is found in the consumables box, located on the left side of the power supply cover.

2. Air hose

- Use an inert gas hose with a 3/8 inch (9.5 mm) internal diameter. Connect it to the gas fitting installed in step 1.

Adjust the air pressure according to the procedure in *Operation* section.

T60M Torch Alignment

Mount the machine torch perpendicular to the workpiece in order to get a vertical cut. Use a square to align the torch at 0° and 90°.

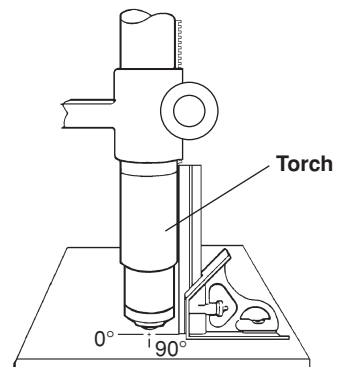

ON/OFF Pendant Connection

Inputs for arc start, with machine torch T60M, are available through the machine interface connection on the rear of the power supply. Plug the Hypertherm remote pendant (see Parts List for part numbers) into the connector on the rear panel.



WARNING

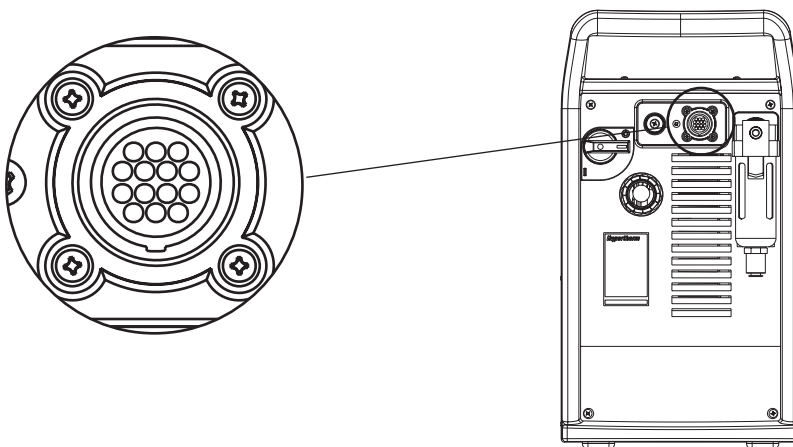

THE ON/OFF REMOTE PENDANT WILL NOT OPERATE WHEN A HAND TORCH IS INSTALLED.



Machine Interface Connection

Signals for arc transfer and start are available through the machine interface connection (see figure above), on the rear of the power supply. Plug the machine interface cable (Part. No. 023206) into the connector on the rear panel. See table below to connect the machine interface cable to the cutting machine

Signal	Start (start plasma)	XFER (start machine motion)
Type:	Input	Output
Notes:	Normally open. 18VDC open circuit voltage at START terminals. Requires dry contact closure to activate.	Normally open. Dry contact closure when arc transfers. 120VAC/1A maximum at machine interface relay or switching device (supplied by customer).
Rear panel sockets	3, 4	12, 14
Cable wires of 023206	Green, Black	Red, Black

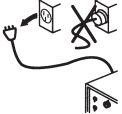
		<p>WARNING ELECTRIC SHOCK CAN KILL</p>
	<p>Disconnect electrical power before performing any maintenance. All work requiring removal of the power supply cover must be performed by a qualified technician.</p>	

Arc Voltage

If arc voltage is necessary for activating a torch height control, the customer must supply an 18 AWG (1.0 mm²), single pair, unshielded cable rated for 300V or greater. All work must be performed following applicable national or local codes.

1. Disconnect power from the power supply.
2. Remove screws that attach the power supply cover to the chassis. Remove the cover.
3. Feed the cable through the strain relief at the rear of the power supply. See figure below.

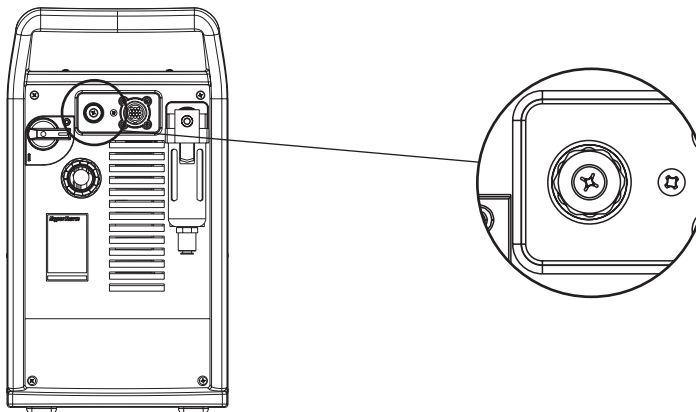

- Find the power board. See figure below. Use insulated type 1/4" faston terminal ends to connect to J15 & J16.

Note: 120VAC or 24 VAC must be sourced externally.

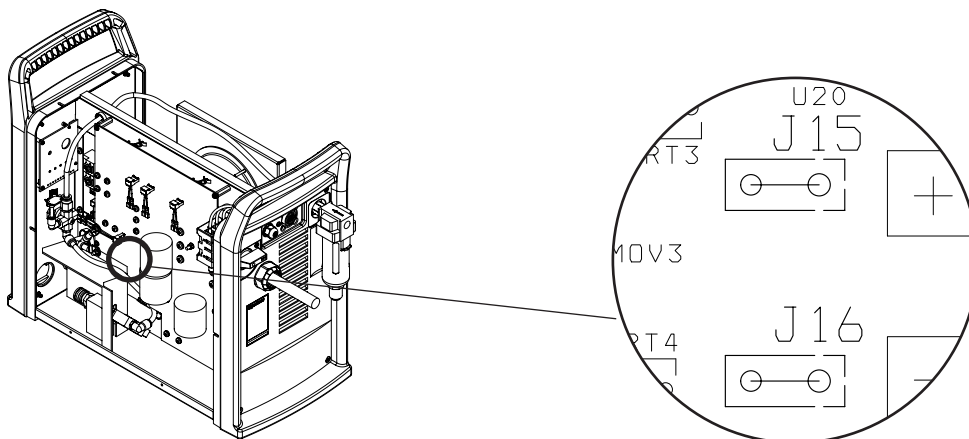

Signal:	Arc Voltage (torch height control)
Type:	Output
Notes:	Full arc voltage. No voltage divider. 300VDC maximum. (Signal not available on rear panel connector.)
J15	+VDC
J16	-VDC

- Tighten strain relief.
- Replace cover

Changing XFER (start machine motion) from dry contact closure to voltage signal

24 VDC (chassis ground reference) at 100ma max is available at J19 on Power PCB to drive a Isolated/Floating device such as a 24 VDC relay coil (240 ohms or greater) or a Typical Industrial Input Isolation Module (which has an opto-coupler built-in). Shown below are typical connections for a high side drive arrangement.

Driving a Relay Coil

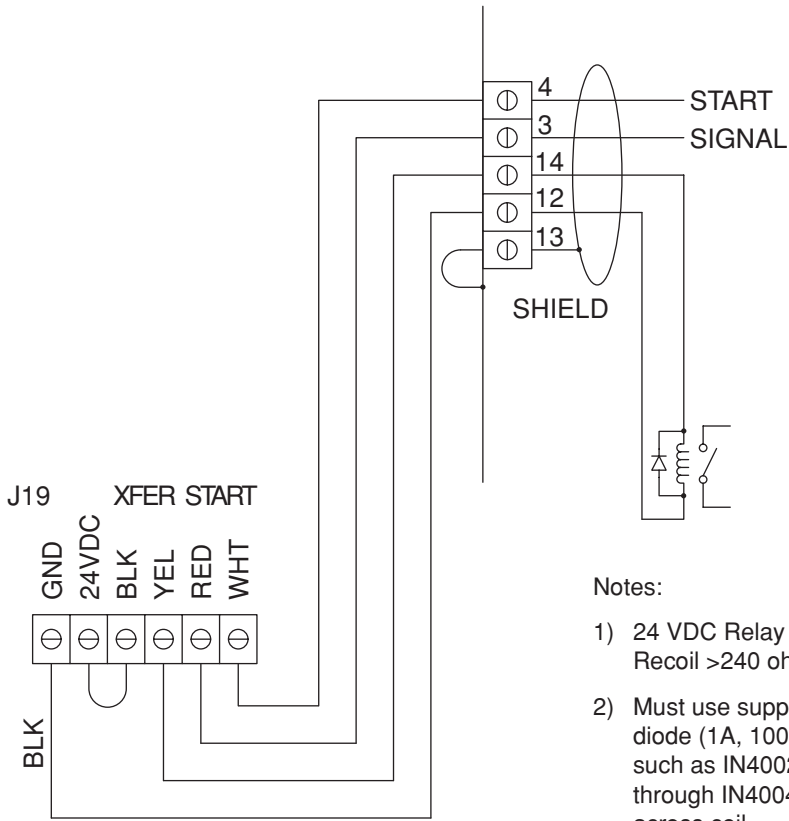

Move Black wire and add Jumper as shown

Notes:

- 1) 24 VDC Relay
Recoil >240 ohms
- 2) Must use suppression diode (1A, 100V) such as IN4002 through IN4004 type through coil.

Driving an Industrial Isolated Input Module

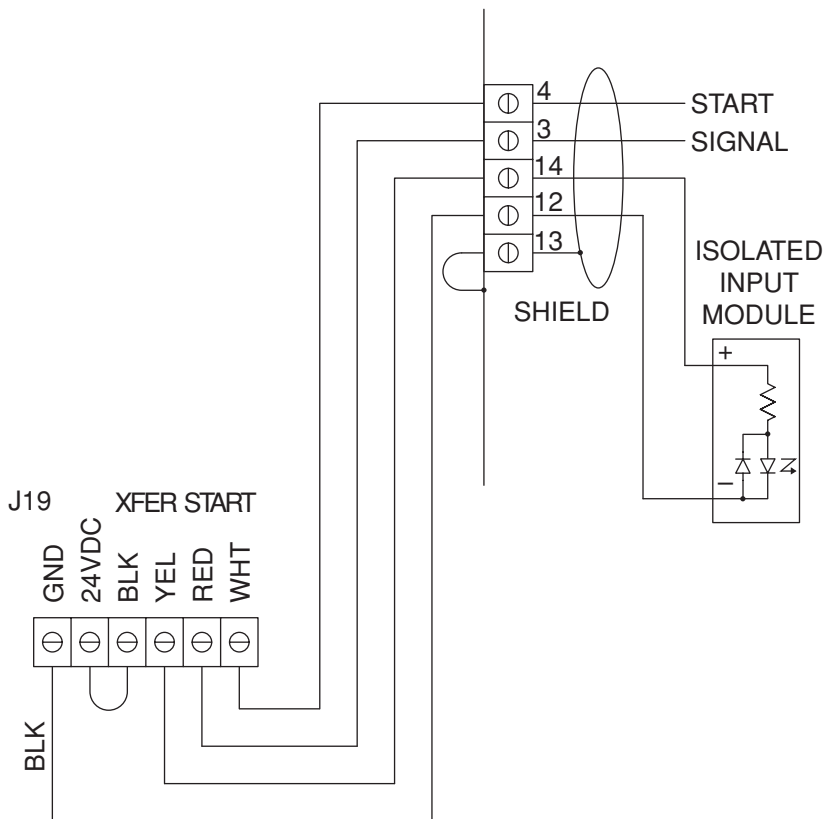

Move Black wire and add Jumper as shown

Section 4

OPERATION

In this section:

Controls and Indicators	4-2
Indicator LEDs	4-2
Torch Consumable Configurations	4-3
Installing Torch Consumables	4-4
Mode Switch	4-5
Turn Power ON	4-5
Check Indicator Lights	4-5
Adjust Gas Pressure and Current Setting	4-6
Hand Torch Operation	4-7
Safety Trigger Operation	4-7
Attach the Work Clamp	4-8
Starting a Cut from the Edge of the Workpiece	4-8
Hand Torch Cutting Technique	4-9
Piercing	4-10
Gouging	4-11
Cut Charts	4-12

Controls and Indicators

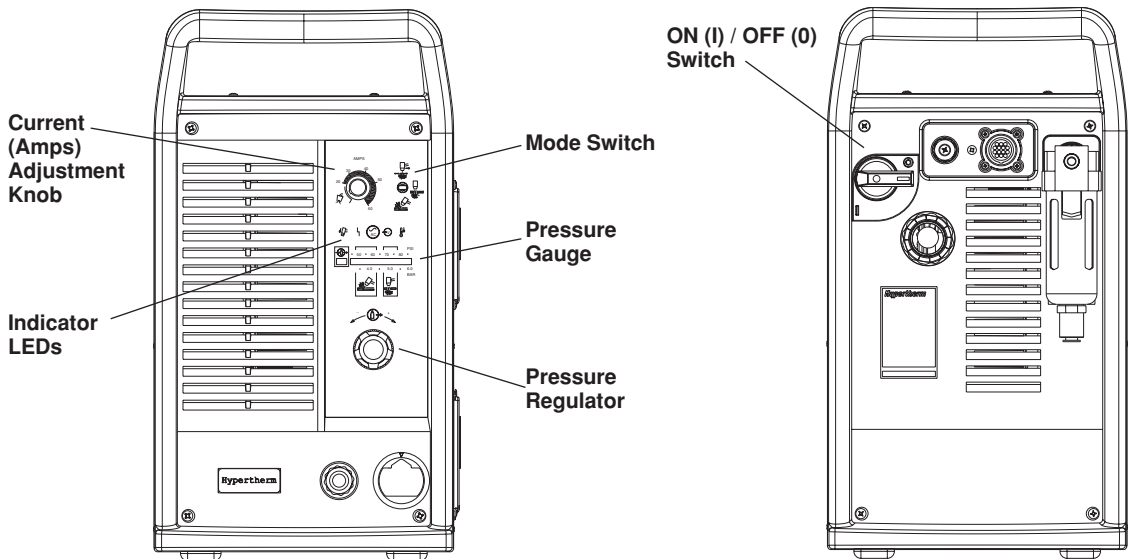

Indicator LEDs



Green Power ON LED

When illuminated, indicates that power is applied to system and power switch is ON (I).



Gas Pressure LED

Yellow: When flashing, indicates that the gas pressure is below 60 psig (4.1 bar) for cutting, or 40 psig (2.8 bar) for gouging.

Green: When illuminated, indicates acceptable gas pressure for torch operation.



Yellow Torch Cap LED

When illuminated, indicates that the Retaining Cap is loose or not installed.

NOTE: Condition must be corrected and power turned OFF then ON to clear LED.



Yellow Temp LED

When illuminated, indicates that the power supply temperature has exceeded its operating limit.



Red Fault LED

When illuminated, indicates that a fault condition exists, which prevents system operation.



Yellow Low Line Voltage LED

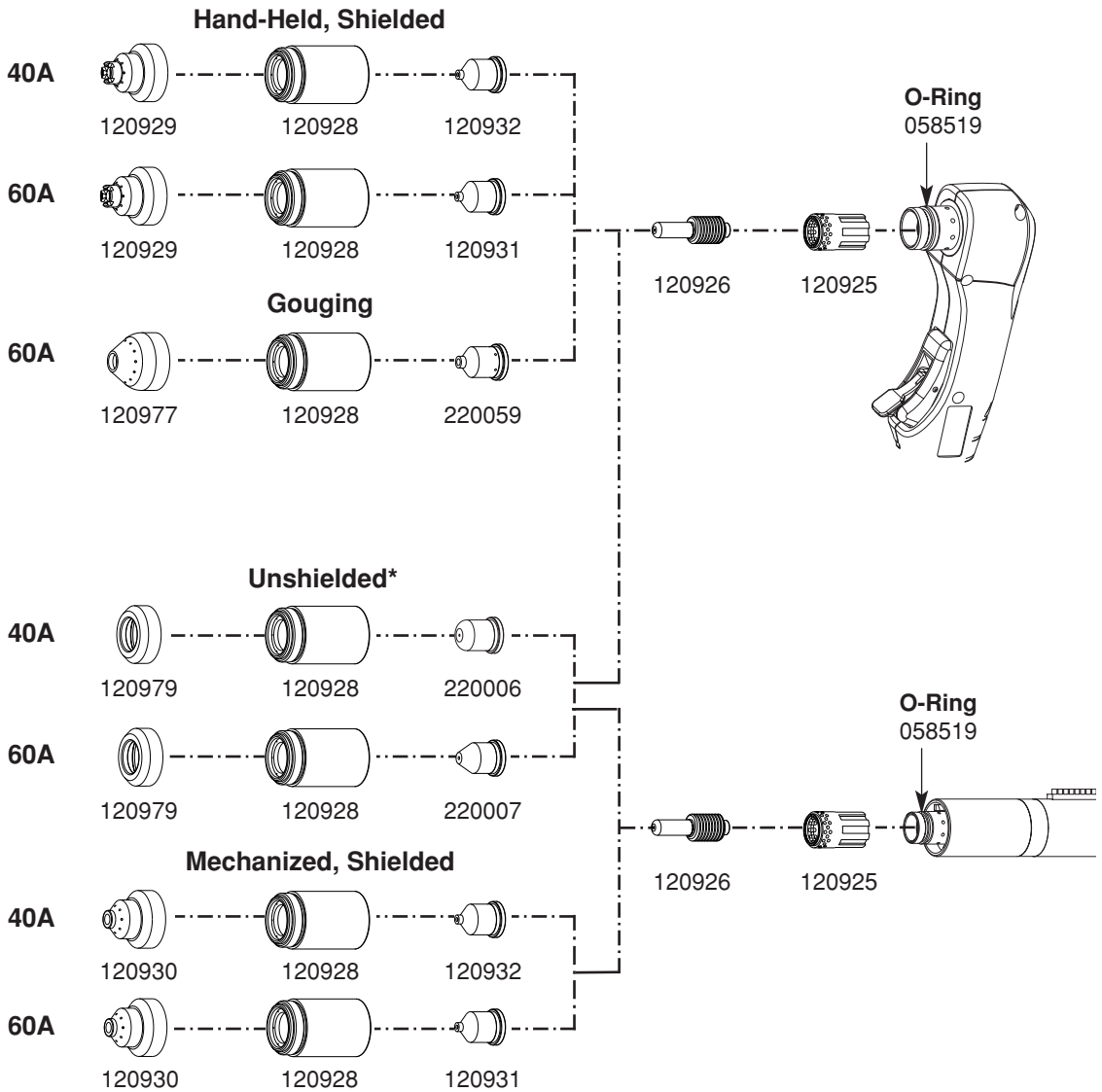

When illuminated, indicates that line voltage is below 170 VAC or above 680 VAC. On CE units, it can also indicate a missing phase.

Torch Consumable Configurations



* In CE countries, unshielded consumables may only be used in mechanized torch applications.

Installing Torch Consumables

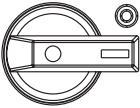
		WARNING INSTANT-ON TORCHES PLASMA ARC CAN CAUSE INJURY AND BURNS
	<p>Plasma arc comes on immediately when the torch switch is activated. The plasma arc will quickly burn through gloves and skin. Make sure power is OFF before changing consumables.</p>	

①

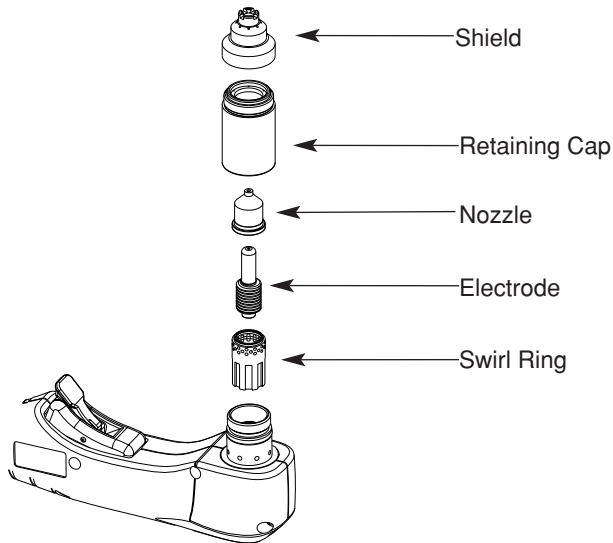

②

Hand tighten only.

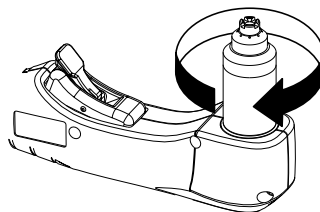

Mode Switch

①

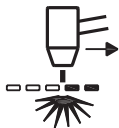

Use to cut expanded metal.
Automatically reinitiates pilot.



Use to cut plate/sheet metal.
Optimum consumable life.



Use to gouge, or for non-transferred-arc operation.

Turn ON Power

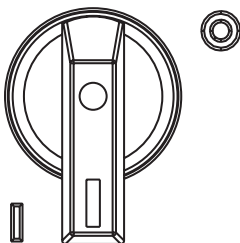

Position the power switch to ON (1) as shown.

Check Indicator Lights



Check that the POWER ON lamp is illuminated.



Check that the Gas Pressure LED is illuminated in Green.

②

Check that the remaining indicator lamps are **NOT** illuminated.

See *Maintenance* Section for details.



Adjust Gas Pressure and Current Setting

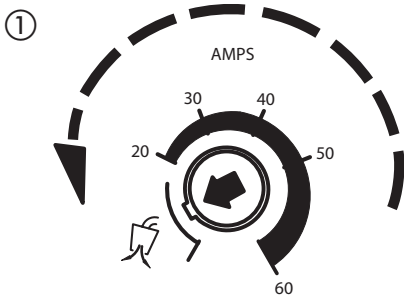

Set current knob to gas test.

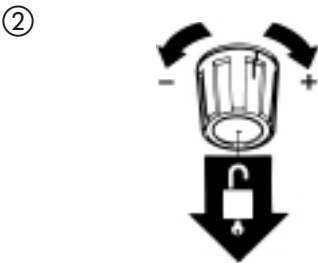

Pull regulator knob to unlock.

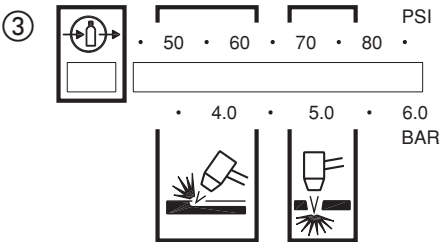

Set pressure:

Cutting 70–75 psig (4.8–5.2 bar)

Gouging 50–60 psig (3.4–4.1 bar)

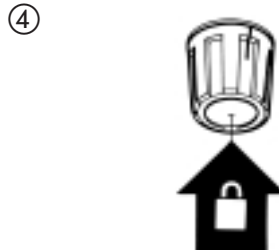

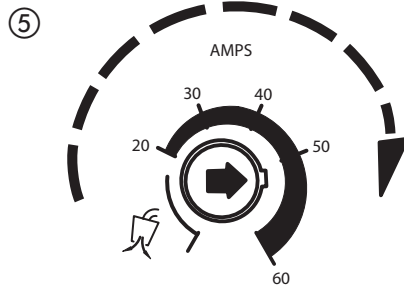

Push regulator knob to lock.



Turn current knob away from gas test to stop gas flow (20 amps minimum).

Hand Torch Operation

		WARNING INSTANT-ON TORCHES PLASMA ARC CAN CAUSE INJURY AND BURNS
<p>Plasma arc comes on immediately when the torch switch is activated. The plasma arc will quickly burn through gloves and skin.</p> <ul style="list-style-type: none">• Keep away from the torch tip.• Do not hold the workpiece, and keep your hands clear of the cutting path.• Never point the torch toward yourself or others.• Never use with Pendant Switch.		

Safety Trigger Operation

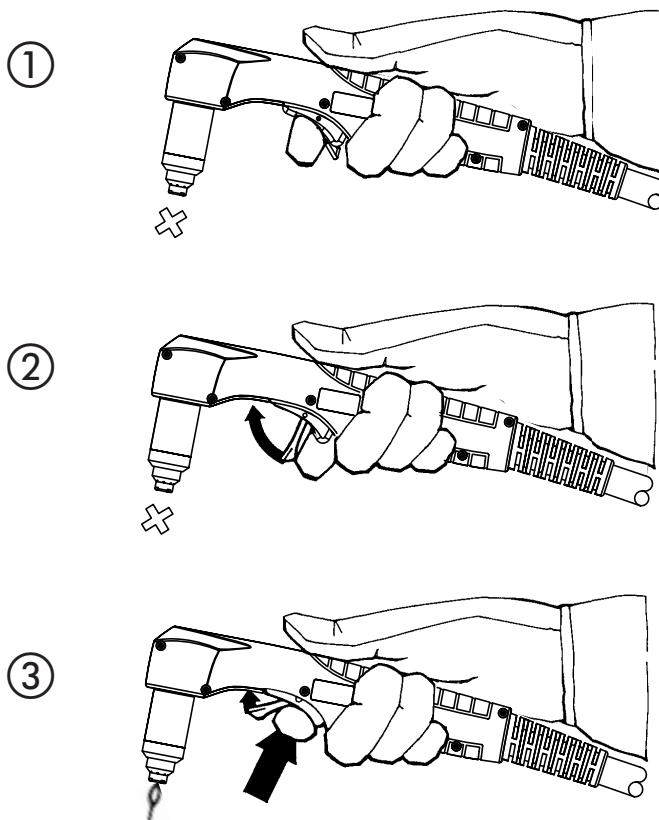

OPERATION

		<p>WARNING SPARKS AND HOT METAL CAN INJURE EYES AND BURN SKIN</p>
<p>When firing the torch at an angle, sparks and hot metal will spray out from the nozzle. Point the torch away from yourself and others.</p>		

Attach the Work Clamp

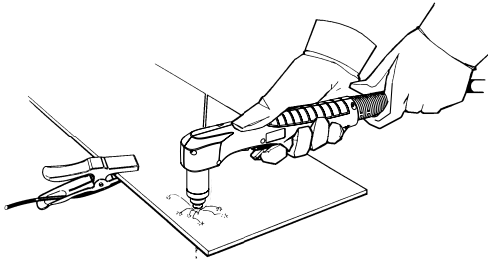

Attach the work clamp securely to the workpiece. Remove rust, paint or other coatings to ensure good electrical contact.

Attach the work clamp as close as possible to the area being cut, to reduce exposure to electromagnetic fields (EMF).

Do not attach the work clamp to the portion that will fall away.

Starting a Cut from the Edge of the Workpiece

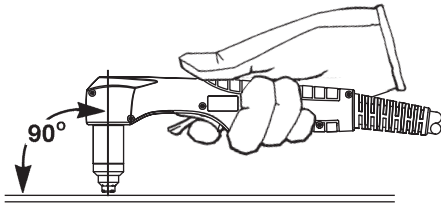

Hold the torch nozzle vertical at the edge of the workpiece.

Start cutting from the edge of the workpiece.

Pause at the edge until the arc has completely cut through the workpiece.

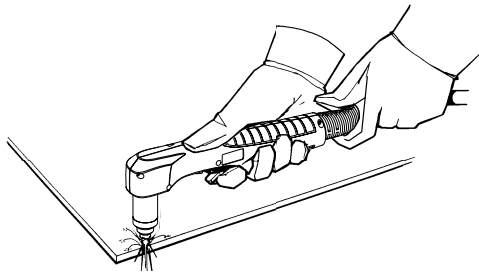

Then, proceed with the cut.

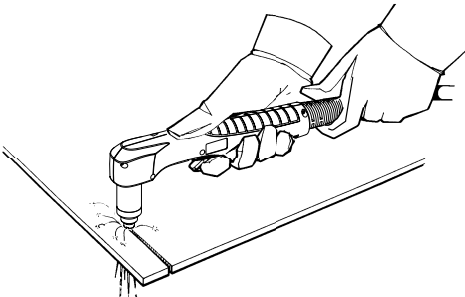

Hand Torch Cutting Technique

Firing the torch unnecessarily reduces nozzle and electrode life.



When cutting, make sure that sparks are exiting from the bottom of the workpiece.

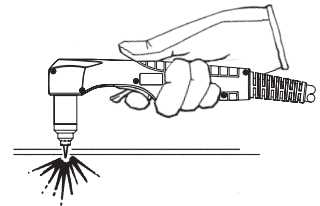

If sparks are spraying up from the workpiece, you are moving the torch too fast, or without sufficient power.

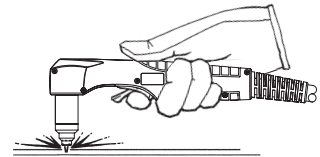

Position the torch nozzle at a vertical position and watch the arc as it cuts along the line.

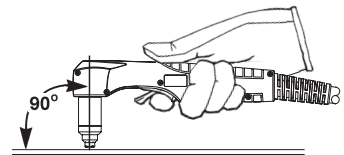

Unshielded Consumables. Maintain an approximate 1/8 inch (3 mm) torch-to-work distance.

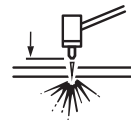

Shielded Consumables. Do not push down on the torch when cutting. Lightly drag the torch across the workpiece to maintain a steady cut.

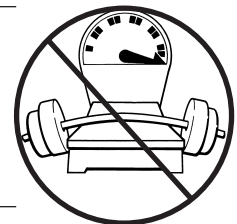

- Pulling the torch through the cut is easier than pushing it.
- To cut thin material, reduce the amps until you get the best quality cut.
- For straight-line cuts, use a straight edge as a guide. To cut circles, use a template or a Hypertherm circle cut guide, Part No. 027668.

OPERATION

Piercing

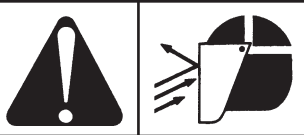
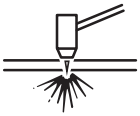

WARNING
SPARKS AND HOT METAL CAN INJURE
EYES AND BURN SKIN

When firing the torch at an angle, sparks and hot metal will spray out from the nozzle. Point the torch away from yourself and others.

Hold the torch so that the nozzle is within 1/8 inch (3 mm) from the workpiece before firing the torch.

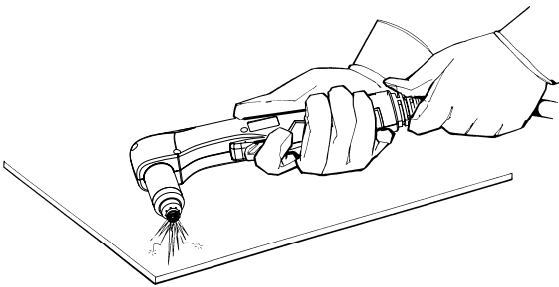

Fire the torch at an angle to the workpiece, then slowly rotate it to an upright position.

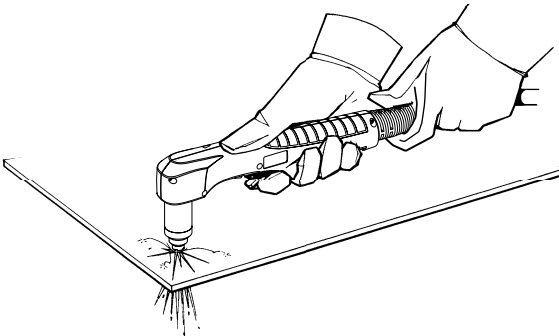

When sparks are exiting from the bottom of the workpiece, the arc has pierced through the material.

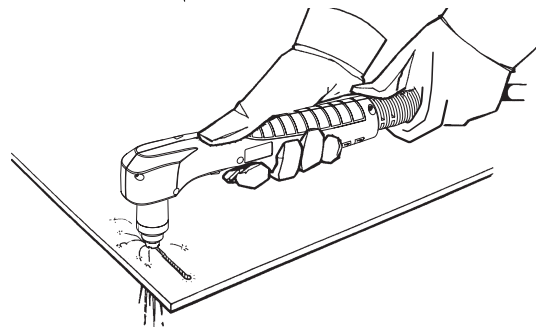

When the pierce is complete, proceed with the cut.

Gouging



		<p>WARNING SPARKS AND HOT METAL CAN INJURE EYES AND BURN SKIN</p>
<p>When firing the torch at an angle, sparks and hot metal will spray out from the nozzle. Point the torch away from yourself and others.</p>		

Hold the torch so that the nozzle is within 1/16 inch (1.5 mm) from the workpiece before firing the torch.

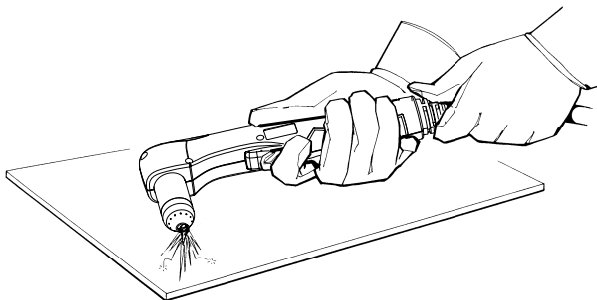

Hold the torch at a 45 degree angle to the work piece. Pull the trigger to obtain a pilot arc. Transfer the arc to the work piece.

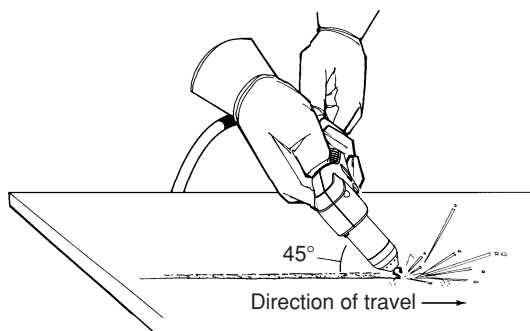

Maintain a 45° angle, approximately, from the workpiece.

Feed into the gouge.

NOTE: A heat shield is available for added hand and torch protection, Part No. 220049.

OPERATION

Cut Charts

60 Amp Mechanized Shielded Consumables

- Torch-to-work distance for the following cut chart is 1/16 inch (1.5 mm) for all cuts.

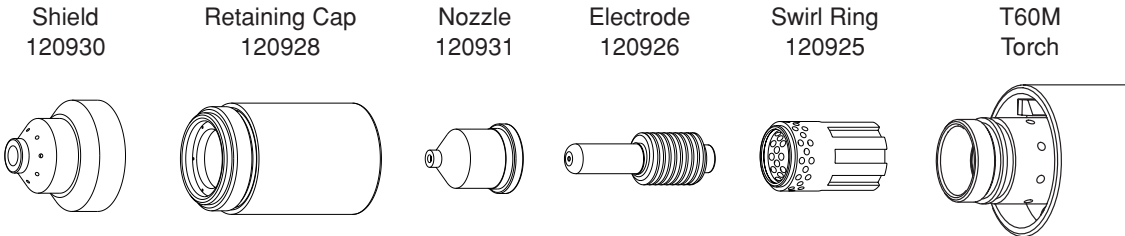

Mild Steel

Arc Current	Arc Voltage	Pierce Delay	Material Thickness		Maximum Travel Speeds		Optimum Travel Speeds	
			Inches	mm	IPM	mm/min	IPM	mm/min
60	134	0	16 Ga	1.5	627	15926	502	12751
	134		10 Ga	3.4	264	6706	211	5359
	138	0.25	1/4"	6.4	132	3353	86	2184
	141	0.75	3/8"	9.5	63	1600	41	1041
	141	1.50	1/2"	12.7	42	1067	27	686
	147		5/8"	15.9	31	787	20	512
	153		3/4"	19.0	22	559	14	363

Stainless

Arc Current	Arc Voltage	Pierce Delay	Material Thickness		Maximum Travel Speeds		Optimum Travel Speeds	
			Inches	mm	IPM	mm/min	IPM	mm/min
60	134	0	16 Ga	1.5	625	15875	406	10312
	136	0.25	10 Ga	3.4	244	6198	159	4039
	139	0.50	1/4"	6.4	110	2794	72	1829
	145	0.75	3/8"	9.5	53	1346	34	864
	146	2.00	1/2"	12.7	35	889	23	584
	149		5/8"	15.9	26	660	17	429
	154		3/4"	19.0	18	457	12	297

Aluminum

Arc Current	Arc Voltage	Pierce Delay	Material Thickness		Maximum Travel Speeds			
			Inches	mm	IPM	mm/min	IPM	mm/min
60	135	0	1/16"	1.6	666	16916	433	10995
	138	0.25	1/8"	3.2	400	10160	260	6604
	141		1/4"	6.4	145	3683	94	2388
	146	0.75	3/8"	9.5	74	1880	48	1219
	149	1.50	1/2"	12.7	51	1295	30	762
	153		5/8"	15.9	33	838	21	545

Maximum travel speeds are the fastest travel speeds possible to cut the material without regard to cut quality. Optimum travel speeds provide the best cut angle, least dross and best cut surface finish. **Remember that cut charts are intended to provide a good starting point for each different cut assignment.** Every cutting system requires "fine tuning" for each cutting application in order to obtain the desired cut quality.

40 Amp Mechanized Shielded Consumables

- Torch-to-work distance for the following cut chart is 1/16 inch (1.5 mm) for all cuts.

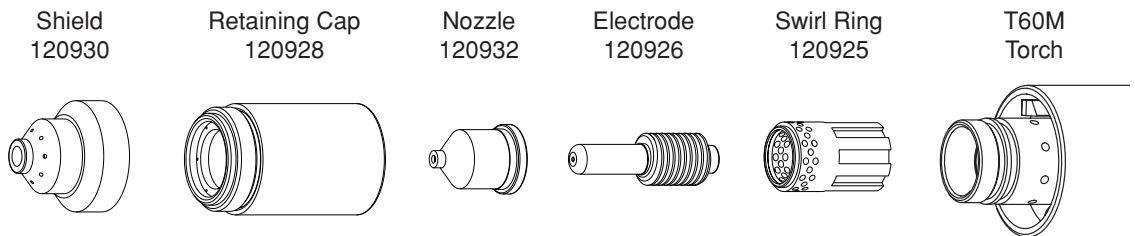

Mild Steel

Arc Current	Arc Voltage	Pierce Delay	Material Thickness		Maximum Travel Speeds		Optimum Travel Speeds	
			Inches	mm	IPM	mm/min	IPM	mm/min
25	147	0	26 GA	0.5	638	16205	415	10541
	148		22 GA	0.8	500	12700	325	8255
	149		18 GA	1.3	312	7925	203	5156
	152		16 GA	1.5	176	4470	114	2896
40	144	0.25	14 GA	1.9	640	16256	221	5613
	146	0.50	10 GA	3.4	151	3835	98	2489
	147	0.75	3/16	4.7	97	2464	63	1600
	149	1.00	1/4	6.4	74	1880	48	1219

Stainless

Arc Current	Arc Voltage	Pierce Delay	Material Thickness		Maximum Travel Speeds		Optimum Travel Speeds	
			Inches	mm	IPM	mm/min	IPM	mm/min
25	139	0	26 GA	0.5	631	16027	410	10414
	139		22 GA	0.8	496	12598	322	8179
40	142	0.25	18 GA	1.3	592	15037	335	8509
	144		16 GA	1.5	374	9500	243	6172
	144		14 GA	1.9	221	5613	144	3658
	147	0.50	10 GA	3.4	107	2718	70	1778
	149	0.75	3/16	4.7	67	1702	44	1118
	149	1.00	1/4	6.4	47	1194	31	787

Aluminum

Arc Current	Arc Voltage	Pierce Delay	Material Thickness		Maximum Travel Speeds		Optimum Travel Speeds	
			Inches	mm	IPM	mm/min	IPM	mm/min
25	150	0	1/32	0.8	610	15494	397	10084
	152		1/16	1.5	268	6807	174	4420
40	146	0.25	3/32	2.4	293	7442	190	4826
	149	0.50	1/8	3.2	204	5182	133	3378
	151	1.00	1/4	6.4	76	1930	49	1245

Maximum travel speeds are the fastest travel speeds possible to cut the material without regard to cut quality. Optimum travel speeds provide the best cut angle, least dross and best cut surface finish. **Remember that cut charts are intended to provide a good starting point for each different cut assignment.** Every cutting system requires "fine tuning" for each cutting application in order to obtain the desired cut quality.

OPERATION

40 Amp Unshielded Consumables

- Torch-to-work distance for the following cut chart is 1/16 inch (1.5 mm) for all cuts.

Deflector
120979

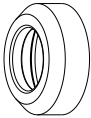

Retaining Cap
120928

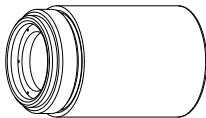

Nozzle
220006



Electrode
120926

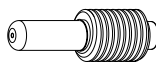

Swirl Ring
120925

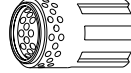

T60M
Torch

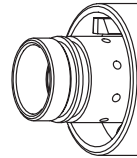

Mild Steel

Arc Current	Arc Voltage	Pierce Delay	Material Thickness		Maximum Travel Speeds		Optimum Travel Speeds	
			Inches	mm	IPM	mm/min	IPM	mm/min
25	125	0	26 GA	0.5	550	13970	353	8966
	128		22 GA	0.8	484	12294	315	8001
	130		18 GA	1.3	238	6045	155	3937
	131		16 GA	1.5	167	4242	109	2769
40	129	0.25	14 GA	1.9	326	8280	212	5385

Stainless

Arc Current	Arc Voltage	Pierce Delay	Material Thickness		Maximum Travel Speeds		Optimum Travel Speeds	
			Inches	mm	IPM	mm/min	IPM	mm/min
25	127	0	26 GA	0.5	561	14249	365	9271
	127		22 GA	0.8	453	11506	295	7493
40	123	0.25	18 GA	1.3	500	12700	325	8255
	127		16 GA	1.5	367	9322	239	6071
	128		14 GA	1.9	220	5588	143	3632

Aluminum

Arc Current	Arc Voltage	Pierce Delay	Material Thickness		Maximum Travel Speeds		Optimum Travel Speeds	
			Inches	mm	IPM	mm/min	IPM	mm/min
25	125	0	1/32	0.8	564	14326	366	9296
	127		1/16	1.5	236	5994	153	3886
40	127	0.25	3/32	2.4	261	6629	170	4318

Maximum travel speeds are the fastest travel speeds possible to cut the material without regard to cut quality.

Optimum travel speeds provide the best cut angle, least dross and best cut surface finish. **Remember that cut charts are intended to provide a good starting point for each different cut assignment.** Every cutting system requires "fine tuning" for each cutting application in order to obtain the desired cut quality.











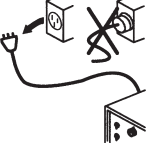

Section 5

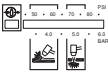
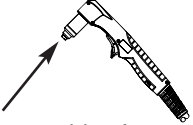
MAINTENANCE AND PARTS

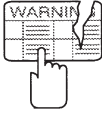
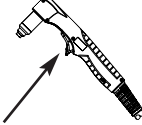

In this section:

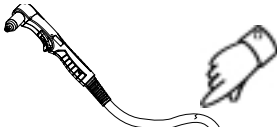
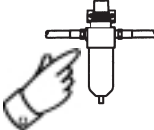
- Routine Maintenance5-2
- Inspect Consumables.....5-3
- Controls and Indicators5-4
- Basic Troubleshooting5-5
- System Circuit Diagram5-8
- Technical Questions5-9
- Parts5-10
 - Torch Consumable Configurations5-10
 - Torch Parts.....5-11
 - Power Supply Parts5-11
 - Accessories5-12

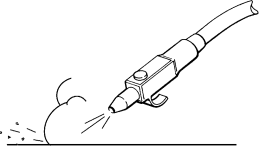
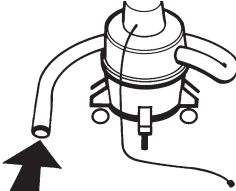
Routine Maintenance

		<p>WARNING ELECTRIC SHOCK CAN KILL</p>	
		<p>Disconnect electrical power before performing any maintenance. All work requiring removal of the power supply cover must be performed by a qualified technician.</p>	
 <p>Each Use</p>	 <p>Check gas pressure.</p>	 <p>Check consumables for wear and proper installation.</p>	
 <p>Each Week</p>		<p>Check torch cap-on safety switch: observe that red fault LED and yellow torch cap LED illuminate when cap is loosened.</p>	
 <p>3 Months</p>	  <p>Replace damaged labels.</p>	 <p>Check trigger for damage. Check torch body for cracks or exposed wires.</p>	
 <p>Replace damaged power cord or plug.</p>	 <p>Replace damaged torch lead.</p>	 <p>Check pressure hose, filter element, and connections for leaks.</p>	
 <p>6 Months</p>	 		<p>Clean the inside of the power supply with air pressure or vacuum.</p>

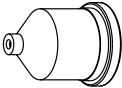
Inspect Consumables

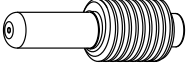
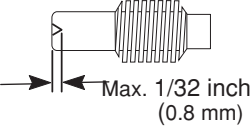
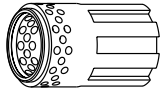
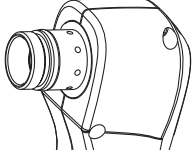
<i>Part</i>	<i>Check For</i>	<i>Action</i>
 <p>Nozzle Center hole</p>	<p>Roundness of through hole</p>  <p>Good</p>  <p>Worn</p>	<p>Replace</p>
 <p>Electrode Center surface</p>	 <p>Max. 1/32 inch (0.8 mm)</p> <p>Maximum pit depth 1/32 inch (0.8 mm)</p>	<p>Replace</p>
 <p>Swirl Ring External surfaces Central bore (I.D.) Gas holes</p>	<p>Damage or debris</p> <p>Does electrode slide easily?</p> <p>Blocked holes</p>	<p>Replace</p> <p>Replace</p> <p>Replace</p>
 <p>Torch O-ring External surfaces</p>	<p>Damage or wear</p> <p>Dry surface</p>	<p>Replace</p> <p>Apply a thin film of Hypertherm grease (Part No. 027055)</p>

Controls and Indicators

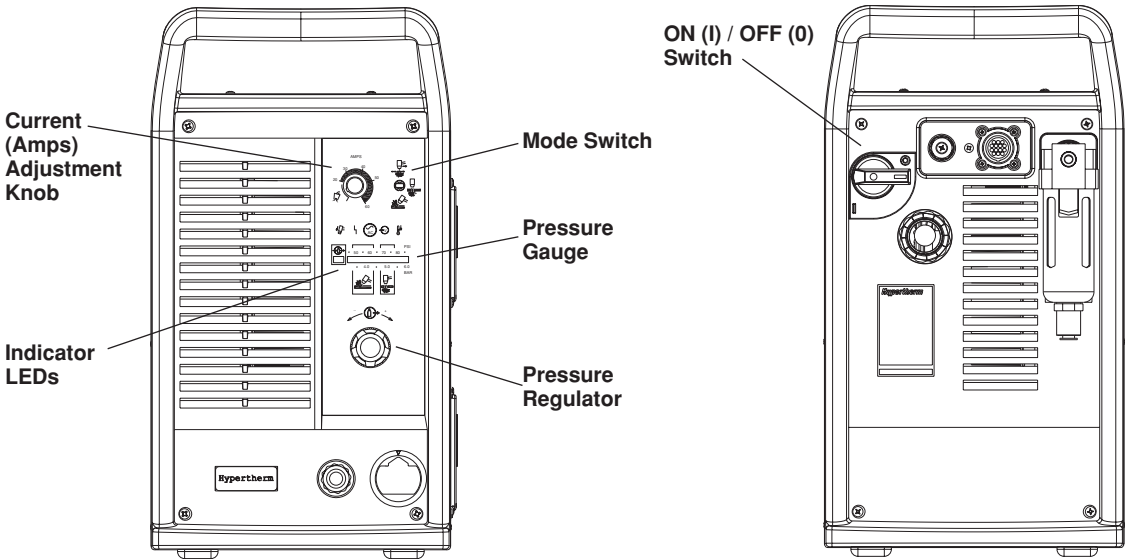

Indicator LEDs



Green Power ON LED

When illuminated, indicates that power is applied to system and power switch is ON (I).



Gas Pressure LED

Yellow: When flashing, indicates that the gas pressure is below 60 psig (4.1 bar) for cutting, or 40 psig (2.8 bar) for gouging.

Green: When illuminated, indicates acceptable gas pressure for torch operation.



Yellow Torch Cap LED

When illuminated, indicates that the Retaining Cap is loose or not installed.

NOTE: Condition must be corrected and power turned OFF then ON to clear LED.



Yellow Temp LED

When illuminated, indicates that the power supply temperature has exceeded its operating limit.



Red Fault LED





When illuminated, indicates that a fault condition exists, which prevents system operation.



Yellow Low Line Voltage LED

When illuminated, indicates that line voltage is below 170 VAC or above 680 VAC. On CE units, it can also indicate a missing phase.

Basic Troubleshooting

Problem	Cause / Solution
<p>1. The ON/OFF power switch is set to I (ON), and the POWER ON (GREEN) lamp is not illuminated.</p>	<p>1.1 The power cord is not plugged into the power receptacle. Plug the power cord into the receptacle.</p> <p>1.2 The disconnect power switch is not set to ON or there is no power available to the disconnect power switch box. Turn on the power at the main power panel or at the disconnect power switch box.</p>
	
<p>Note: Fan on/off is automatic. Fan may not be in operation when power is ON.</p>	
<p>2. The POWER ON (GREEN), LOW GAS PRESSURE RANGE (YELLOW) is flashing and FAULT (RED) lamps are illuminated.</p>	<p>2.1 The gas supply is turned OFF or not connected to the power supply. Check that the gas is turned on and is connected to the power supply.</p> <p>2.2 The incoming gas pressure is too low. Set incoming gas pressure to 90-120 psig / 6.2-8.3 bar. Check that there are no leaks in the gas supply line.</p> <p>2.3 Output gas pressure is set too low for selected mode. Adjust gas pressure. See page 4-6 (item 3) for pressure settings.</p>
	
<p>3. The POWER ON, LINE VOLTAGE RANGE (YELLOW) and FAULT (RED) lamps are illuminated.</p>	<p>3.1 Line voltage is too low, too high, or a phase (CE system only) is missing. Have a qualified technician check incoming power.</p>
	
<p>4. The POWER ON (GREEN), TEMPERATURE (YELLOW) and FAULT (RED) lamps are illuminated.</p>	<p>4.1 One of the internal thermostat switches has opened due to overheating or extremely low temperature. Leave the power supply on to allow the fan to cool the power supply (overheating). Move the power supply to a warm location (extreme cold).</p>
	

Basic Troubleshooting (continued)

Problem	Cause / Solution
<p>5. The POWER ON (GREEN), TORCH PARTS LOOSE OR REMOVED (YELLOW) and FAULT (RED) lamps are illuminated.</p>	<p>5.1 Retaining Cap is loose or removed from the torch. Turn off power supply and tighten or install torch consumables. See <i>Installing Torch Consumables</i>, Section 4.</p> <p>If the torch consumables become loose or were removed while the power supply is on, turn off the power supply, correct the problem and then turn on the power supply to clear this fault.</p>
	
<p>6. The arc does not transfer to the workpiece.</p>	<p>6.1 The work clamp is not connected to the workpiece, or the work clamp is broken. Connect or repair the work clamp.</p> <p>6.2 The work clamp is not making good metal-to-metal contact. Clean the area where the clamp contacts the workpiece.</p> <p>6.3 The torch is too far away from the workpiece. Move the torch head closer to the workpiece and start the torch again. See <i>Torch Operation</i>, Section 4.</p>
<p>7. The arc blows out, but re-ignites when the torch switch is depressed again.</p>	<p>7.1 The consumable parts are worn or damaged. Inspect and change the consumables, as necessary. See <i>Inspect Consumables</i>, in this section. See <i>Torch Operation</i>, Section 4.</p> <p>7.2 The gas pressure is incorrect. Adjust the operating gas pressure. See <i>Check and Adjust Gas Pressure</i>, Section 4. Check that the gas pressure to the power supply is not less than 90 psig (6.1 bar) at a flow of 6 scfm (189 l/m).</p> <p>7.3 The gas filter element outside the power supply is contaminated. Replace filter element. See <i>Air Filter Element Replacement</i>, in this section.</p>

Basic Troubleshooting (continued)

Problem	<i>Cause / Solution</i>
8. The arc sputters and hisses.	<p>8.1 <i>The gas filter element outside the power supply is contaminated.</i> Replace filter element.</p> <p>8.2 <i>There is water in the air line.</i> Clean air filter or add additional air filtration to power supply. See <i>Additional Gas Filtration</i>, Section 3.</p> <p>8.3 <i>Worn or incorrectly installed consumables.</i> Inspect consumables. Replace if necessary.</p>
9. Cut quality is not good.	<p>9.1 <i>Consumables are worn or the torch is being used incorrectly.</i> See <i>Inspect Consumables</i>, in this section. See <i>Hand Torch Operation</i>, Section 4.</p>
10. The POWER ON (GREEN) and FAULT (RED) lamps are flashing.	<p>10.1 <i>Self diagnostic failure.</i> System needs repair.</p>
11. The POWER ON (GREEN) and FAULT (RED) lamps are illuminated after power is turned on.	<p>11.1 <i>Start signal ON when system power is initiated.</i> Turn start signal OFF. Turn power OFF and then ON again.</p>
12. The POWER ON (GREEN) and FAULT (RED) lamps are illuminated for 10 seconds after trigger switch is activated.	<p>12.1 <i>Consumables stuck or jammed.</i> Turn power OFF and Check consumables.</p>

System Circuit Diagram

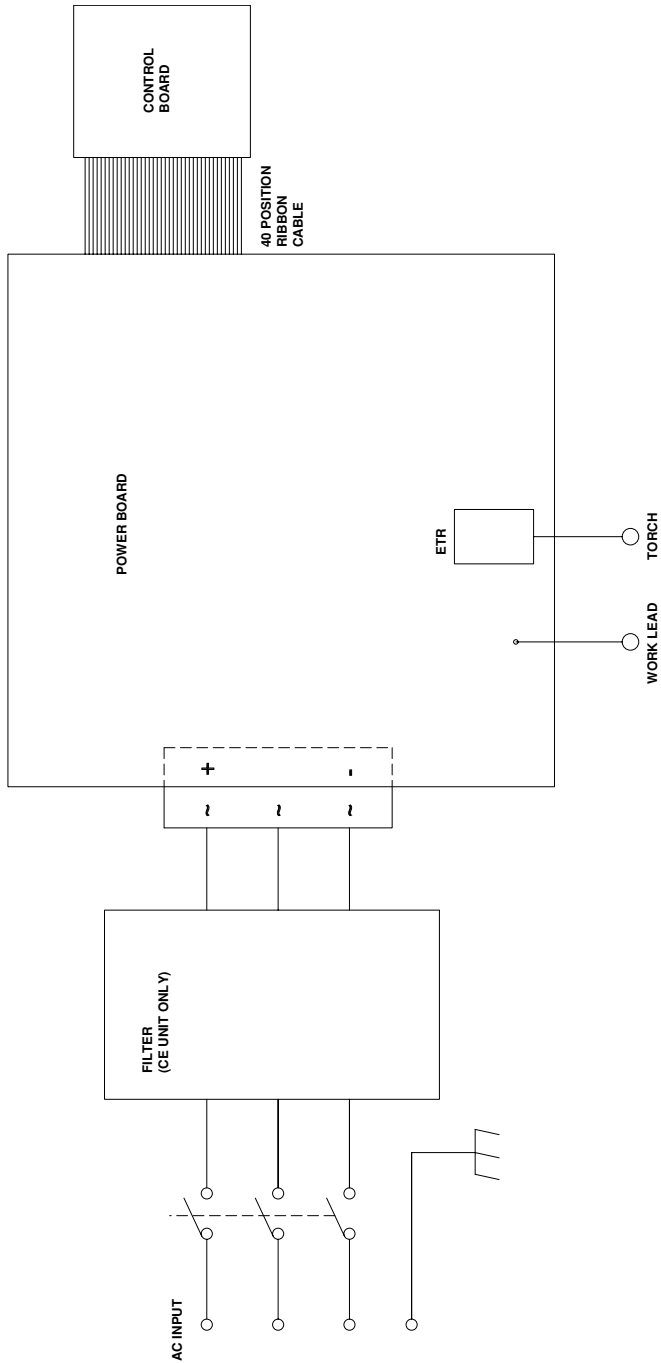

Technical Questions

If you are unable to fix the problem by following this basic troubleshooting guide or if you need further assistance:

1. Call your Hypertherm distributor or authorized Hypertherm repair facility.
2. Call the nearest Hypertherm office listed in the front of this manual.
3. Request a Powermax1000 Service Manual for wiring diagrams, higher-level troubleshooting and more parts list information.

Parts

Torch Consumable Configurations

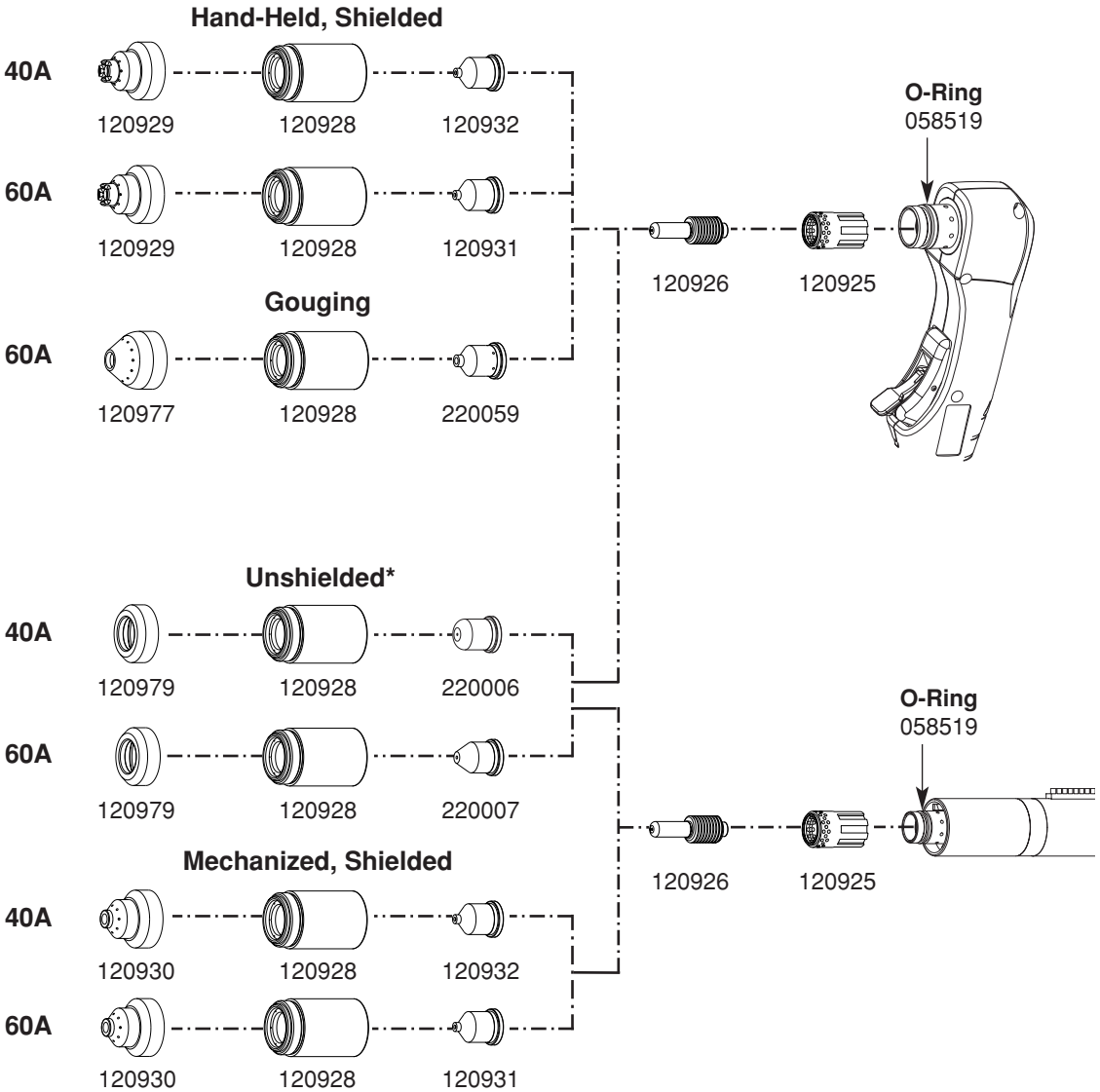

* In CE countries, unshielded consumables may only be used in mechanized torch applications.

Torch parts

083172	T60 Hand Torch Assembly, 25'
083171	T60 Hand Torch Assembly, 50'
083175	T60M Machine Torch Assembly, 15'
083174	T60M Machine Torch Assembly, 25'
083176	T60M Machine Torch Assembly, 35'
083177	T60M Machine Torch Assembly, 50'
027055	Silicon Lubricant, 1/4 Oz. Tube
015337	NIP: 1/4 NPT Qdisc STL (Non-CE)
015145	Adapter: 1/4 NPT x G1/4 BSPP RH BRS (CE)
058519	Torch O-Ring
128644	T60 Hand Torch Handle Replacement Kit (5 Screws included)
075586	T60 Hand Torch Handle Screw (5 Required)
220061	Shield Cap: T60M/T80M Ohmic Contact

Power Supply Parts

083178	Powermax 1000 Hand System, 200-600V, 1/3PH, 50/60Hz, CSA, Auto-Voltage/Phase (Not CE Compliant), 25 Ft. Torch & Lead Assembly
083179	Powermax 1000 Hand System, 200-600V, 1/3PH, 50/60Hz, CSA, Auto-Voltage/Phase (Not CE Compliant), 50 Ft. Torch & Lead Assembly
083182	Powermax 1000 Machine System, 200-600V, 1/3PH, 50/60Hz, CSA, Auto-Voltage/Phase (Not CE Compliant), 25 Ft. Torch & Lead Assembly
083183	Powermax 1000 Machine System, 200-600V, 1/3PH, 50/60Hz, CSA, Auto-Voltage/Phase (Not CE Compliant), 50 Ft. Torch & Lead Assembly
083192	Powermax 1000 Hand System, 230-400V, 3PH, 50/60Hz, CE, Auto-Voltage, 25 Ft. Torch & Lead Assembly
083193	Powermax 1000 Hand System, 230-400V, 3PH, 50/60Hz, CE, Auto-Voltage, 50 Ft. Torch & Lead Assembly
083194	Powermax 1000 Machine System, 230-400V, 3PH, 50/60Hz, CE, Auto-Voltage, 25 Ft. Torch & Lead Assembly
083195	Powermax 1000 Machine System, 230-400V, 3PH, 50/60Hz, CE, Auto-Voltage, 50 Ft. Torch & Lead Assembly
110394	Cover Assembly, Non-CE (12 Screws Included)
110395	Cover Assembly, CE (12 Screws included)
075533	Cover Screws (Individual Cover Screw)
128627	Filter Bowl w/ Fittings
129654	ETR Door Assembly
129405	Consumable Box
123645	Ground Clamp w/ Cable & Strain relief
129652	Power Cable, Standard 3PH
129726	Power Cable, CE, 3PH

Accessories

128646	Wheel Kit
128647 011093	Optional Air Filtration Kit Replacement Filter For Optional Air Filtration Kit
011092	Replacement Filter Element For Filter Kit
027668	Circle Cutting Guide Assembly
027684	Replacement Bushing for Circle Cutting Guide Assembly
123646	50 Ft (15M) Work Cable w/ clamp
128711	CE Stain Relief Inserts - Standard Cord
128712	CE Strain Relief Inserts - Non-standard Cord
023206	CNC Interface Cable
220049	Hand Heat Shield, Gouging
128650	On/Off Pendant for Machine Torch, 25 Ft (7.5M)
128651	On/Off Pendant for Machine Torch, 50 Ft (15M)
128652	On/Off Pendant for Machine Torch, 75 Ft (22.5M)